

Calf Manual

Information for healthy and high performance calf rearing



Contents

	CalfExpert The trendsetter in calf feeders	6		CalfGarden Single pen canopy for protected outdoor climate housing	64
	HygieneStation New standard of hygiene for calf feeders	12		PenSystem Flexible pen design thanks to modular plug-in system	68
	WholeMilkPlus State-of-the-art whole milk feeding for calf feeders	18		FeedFence Safe and practical feeding place design	72
	CalfGuide Practical management software for modern calf rearing	24		CalfHealth Aids for a healthy start in life	78
	MilkTaxi More than a mobile milk tank: individual feeding and optimum hygiene	28		SpecialistArticle Valuable information on all aspects of calf husbandry	82
	WeightControl Flexible weight measurement	38		Layout Examples CalfExpert	94
	Calfgloo Outdoor social group husbandry	44		Layout Examples igloo barns	100
	IglooVeranda Weather protection for outdoor group housing	48		Service, training, events	102
	MultiMaxVeranda Variable small group housing in outdoor climate	52			
	TwinHutch Modern pair husbandry, also following organic guidelines	56			
	FlexyFence Flexible and hygienic individual housing	60			

Holm&LAUE

Year	Milestones
1991	Founding of company and development of the first calf feeders HL 2000 and HL 25
1994	Holm & Laue develops weight-responsive ration quantities for automatic calf feeders
1996	Introduction of the HL Joker calf feeder with two blending units
1998	The Holm & Laue jumbo igloo is introduced; the TOM water blending system is awarded the DLG silver medal.
2000	The H&L 100 calf feeder replaces the HL Joker
2002	The H&L IglooSystem is expanded into a well thought-out natural outdoor climate rearing concept
2004	EuroTier 2004 - DLG Press innovation award for the H&L IglooVeranda
2005	The H&L MilkTaxi complements the portfolio
2006	Introduction of a pasteuriser for calves' milk as an optional item for the MilkTaxi
2009	The CalfGarden and the MultiMax Veranda are developed and the portfolio expanded to include Calf-Tel individual igloos and the pen system

Year	Milestones
2010	The coloQuick colostrummanagement system is introduced, and both coloQuick and MilkTaxi win DLZ's Innovation Award of that year
2011	The FlexyFence for Calf-Tel individual hutches is developed
2013	Launch of the CalfGuide management software for the H&L 100
2015	HygieneStation – new hygiene standard at automatic calf feeders
2016	MilkTaxi 4.0 receives DLG silver medal, TwinHutch: the first calf hutch for mini groups of 2-3 calves
2018	DoubleJug and MiniFlash complete the whole milk strategy
2019	CalfExpert, the new innovative generation of automatic feeders
2020	Development of the ConceptBarn
2021	Brix-TS Sensor in the CalfExpert wins DLG silver medal and the French InnovSpace
2022	WeightControl weighing scales system added to the product range



Passionate about
healthy calves



Welcome to Holm & Laue

Since 1991, we have been supplying products that have established themselves all over the world as the cornerstones of state-of-the-art and performance-aware calf rearing. Again and again, the products that we developed were able to make your work for the calves easier, to improve the state of health and the performance of the animals and to reduce the cost and work time needed for rearing calves.

At Holm & Laue, you can be sure that you will be supplied with tried and tested products which have been developed exclusively by people who know your everyday practice because they are rooted in a farming operation themselves. For Holm & Laue offers you more than just state-of-the-art technology: we endeavour to be your partner on all issues raised by calf rearing. Our team is at your service providing advice on planning your new calf housing facility, tips for daily calf feeding practice and improved calf health. It is only when you are 100 percent satisfied, when your work has become easier and your results have improved that we, too, are satisfied.

Our calf manual is intended to give you an overview of our work. We look forward to productive cooperation.

A. Laue *Hans Joachim Holm*

Hans-Joachim Laue

Hans Joachim Holm

CALF EXPERT



The **trendsetter** in
calf feeders



Calf feeding made easy

Calf feeders from Holm & Laue are sturdy, easy to operate and always guarantee healthy and strong calves thanks to individual mixing and hygienic preparation of the milk diet. The CalfExpert is a feeder that sets new standards in the market. The result: even more intelligent, even faster and even more functions to make your work easier and guarantee optimum feeding of your calves. You will soon see how the CalfExpert revolutionises your work with calves – you always have all the important information at your fingertips: at the feeder, at the HygieneStation or on your mobile phone. Not only preparation of the milk diet is speeded up, automatic cleaning is faster too. At last, whole milk feeding is just as convenient as feeding milk replacer (CMR). In combination with the DoubleJug milk cooling tank, the CalfExpert controls its functions automatically, including the cleaning of all lines and tanks. We are particularly proud of the operation of the CalfExpert: we consciously decided against touch control – or have you never tried to use your mobile phone with dirty fingers, wearing gloves or in the winter? We are convinced that our SmartKeys and the 7" display provide you with the ideal operating concept. Take a look at the next few pages and discover the many possibilities provided by the new CalfExpert calf feeder.



Gain greater freedom through increased work flexibility. Data analysis via app aids professional management.



Better rearing performance thanks to weight measurement with weighing scales. Lower veterinary costs through automatic animal monitoring and early alerts.



Promote natural drinking behaviour: many individual feeds support the healthy development of the calves.



Individual animal feeding

Feeding a large number of calves with a fresh mix adapted to each individual calf is an enormous challenge. The CalfExpert has mastered this perfectly.

Always freshly mixed

The milk for each calf is always freshly mixed by the CalfExpert. Any residual milk is kept warm and flushed out of the system following longer drinking breaks. Other calf feeders work with a central milk supply. In milk stored this way at 40 °C, the germ count doubles every 20 minutes. In contrast, the CalfExpert guarantees maximum hygiene and feeding suitable for every individual animal.

Individual adaptation

A central milk supply has another decisive disadvantage: modern feeding programs (e.g. the metabolic programming) require a higher CMR concentration at the start of rearing (e.g. 160 g/l) to give a power pulse. In the milk reduction phase however, a lower concentration is needed (130 g/l). This individual animal feeding can only be achieved if the mix is prepared individually for each calf, as is the case with CalfExpert.

"Brix-TS" for consistent mixtures

The electronic Brix sensor integrated into the CalfExpert mixing bowl continuously measures the dry matter of the freshly mixed calf milk. allowing, deviating mixing concentrations of milk replacer to be detected. The CalfExpert control then corrects the concentration of the milk to ensure that the correct milk mixture is always prepared.

"QuickChange" logic for more performance

With the new CalfExpert we have designed the mixing process and calf changeover to be even faster and thus optimised utilisation of the HygieneStations. The fast mixing ensures that the milk is at the stall after only 3 seconds. After the last mix, the system changes immediately to the second stall and a further calf is fed. In addition, priorities can be specified in the CalfExpert menu so that young or sick calves are given preferential treatment. The tried-and-trusted flexitime program is an additional guarantee that the calves' feeding times are spread very evenly throughout the day without the animals clustering around the stalls. This reduces waiting times for high animal capacities and ensures calves have a positive "visit experience".

QuadroFlex: simultaneous and yet flexible feeding

With the new QuadroFlex system, four calves can feed at the same time at two PowerMixers. The CalfExpert mixes the milk freshly when calves wish to drink. This means no tank supply system is required. The feeding quantity is determined precisely for each calf by maintenance-free sensors. If a calf requires a special mix e.g. including medicine or electrolytes, only the sister stall at the same PowerMixer is switched off. Calves can continue to feed at both stalls at the second PowerMixer. This allows 120 calves to be fed at 4 HygieneStations. Thus the capacity of the CalfExpert has been increased by approx. 20 – 30 % compared to its predecessor H&L 100.



Enjoy calm and compliant calves

Since CalfExpert does not restrict feeding to certain times of day, calves can come and feed at any time. Your calves will no longer see you as a nurse and will therefore remain calm when people enter the barn. Younger and weaker calves have all the time they need to consume their full ration. And since the CalfExpert works with an intelligent credit logic, all the calves have drinking credit at different times. As a result, fewer animals crowd around the station. And the anti-pirate valve ensures that stronger calves do not steal milk. You'll see the result: very uniform, relaxed groups of calves!

Weaning process

The CalfExpert is very gentle as it prepares the calves' transition to concentrate and forage feed. At the end of the milk diet stage, it reduces the allocated quantity in small steps of 0.1 l per day, thereby stimulating the development of the forestomach system.



Flexible feeding programs

Modern feeding programs should always be adapted to the age, race, personal rearing target or health of the calves. You can implement all this ideally at the CalfExpert.

8 feeding curves for maximum flexibility

CalfExpert can be used to turn any feeding programme into reality. The feeding curves can be adapted extremely flexibly in each of the 8 groups. Up to 16 "turning points" allow you to fine-tune your personal feeding concept down to the last detail. Or you decide in favour of one of the proven and pre-set CalfExpert feeding programmes.

Metabolic programming

Intensive feeding in the first few weeks of a calf's life will usually lead to significantly higher milk production later. However, the right reduction of milk for calves e.g. after an ad libitum phase presents every calf owner with special challenges. With the CalfExpert, every calf is weaned slowly off a high milk consumption in terms of both volume and concentration.

Metabolic Feeding Programme with the CalfExpert

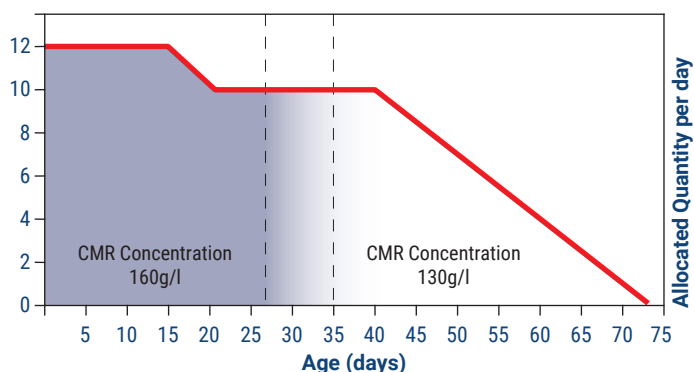

Effective mixing of milk replacer powder

Flexible feeding also means that a wide range of CMRs and additives have to be prepared in an optimum and lump-free way. The continuously variable PowerMixer guarantees a soft start to avoid splashes and then stirs the milk replacer powder intensively. This means the calf receives its freshly mixed milk directly at the teat in just 3 seconds.

And if things should take longer?

The feeding process can sometimes take longer where young or weak calves are involved. We prevent the separation of the milk replacer powder by slow permanent stirring. And if it gets colder, the heater in the mixer always ensures the mix is kept at a constant temperature, for no matter how long the calf needs.

Specific additive feeding

Minimal doses of feed additives can be added to the milk diet in order to stabilise the gastrointestinal system. Sick calves can be treated with medicines in the milk. You can use two powder dosing units and two liquid dosing units. As with the milk programme, you can set different feeding curves for these additives as well. This means maximum flexibility for top calf health.



Higher income thanks to improved performance

Calves supplied with a lot of energy start lactation at an earlier age and produce more milk later on. CalfExpert also provides you with the best prerequisites for optimum animal health. This means a lower death rate and more animals in the herd reared from your herd offspring. This in turn gives you the opportunity to select the offspring in a targeted manner and to sell surplus heifers at a profit. And last but not least: by saving working time, you are freeing up capacities on your farm that can be used profitably.



Clean & reliable

A calf feeder is designed to make your work easier and perform continually for 24 hours. To achieve this it has to work reliably under the rough conditions of a calf stall, like the CalfExpert does.

Hose cleaning including the teat

All hose systems used to have deposits of contaminated milk because they had not been cleaned often enough or thoroughly enough. The HygieneStation rinses the entire milk hose through to the teat during longer drinking breaks. In addition, the complete milk system is cleaned several times every day. When the DoubleJug is used, the supply line to the CalfExpert is automatically cleaned with it. This will reduce a calf's exposure to bacteria, improve the health of the calves and save on manual cleaning.

Two cleaning agents

The CalfExpert can use two different cleaning agents to further optimise cleaning – either alternating with each cleaning cycle or combined in one cleaning cycle: (alkaline, rinse, acid, rinse). The cleaning agent pumps are fitted on the outside. They can thus draw directly from the tanks. This is safe and convenient. In addition, the CalfExpert generates automatic messages as soon as a canister is empty.



Integrated operating instructions

The 7" graphic display not only allows all calf data to be conveniently viewed. Pressing the key with the book icon opens help texts and information from the operating instructions at every level of the application.

Fly shield as standard

Two large doors protect the critical area where the mixer bowls are located. This keeps flies away from the milk and avoids problems in the milk system. The doors can be locked so children cannot be harmed or injured.

Ready to work whatever the weather

Calves love the outdoor climate, your CalfExpert does too. It comes with a frost protection programme that is activated automatically as soon as there is a risk of frost. Sensors in every HygieneStation and in the CalfExpert mixing chamber measure the ambient temperature and then adapt the mixing temperature and intensity of the frost protection programme accordingly. You can clean the outer surfaces of the automatic feeder with water, since all the sensitive components are water spray-proof.

Simple maintenance

Checking the equipment regularly is easy: the maintenance menu allows you to test all important components of the CalfExpert quickly and easily. You can also carry out calibration quickly yourself, because the software always tells you exactly what to do. We recommend that you have your CalfExpert serviced by a qualified technician at least once a year. This provides you with the peace of mind that the automatic feeder will be ready for the next rearing cycle.

Automatic calibration

The CalfExpert checks the flow rate of milk and water at regular intervals, ensuring a consistent amount of water for the calves without your needing to actively worry about it. Although this unfortunately does not apply to the amount of powder, the machine will remind you as soon as calibration needs to be performed. However, with its Brix-TS option (see p. 8), CalfExpert compensates for deviations in the mix concentration, so that you are always sure that the calves have been fed correctly.



Work more smartly

Kill two birds with one stone: the CalfExpert not only relieves you of tiresome and tiring jobs, it also increases feeding quality.

Gain time and flexibility

Take care of your calves when YOU want and don't let them dictate your day. There are often other jobs and responsibilities to be taken care of in the mornings and evenings in particular: milking and feeding the cows, making breakfast for the family or taking your children to school... CalfExpert feeds your calves. You only have to monitor the machinery and the animals. And training is reduced to a minimum with the new HygieneStation.

CalfExpert software

The completely new control software offers maximum clarity and simple CalfExpert operation. All calf data with individual feeding curve, alarm lists, technical parameters etc. can be viewed on the 7" display. Via the Wi-Fi connection you can also access individual data on mobile devices or receive push messages in the event of fault messages.

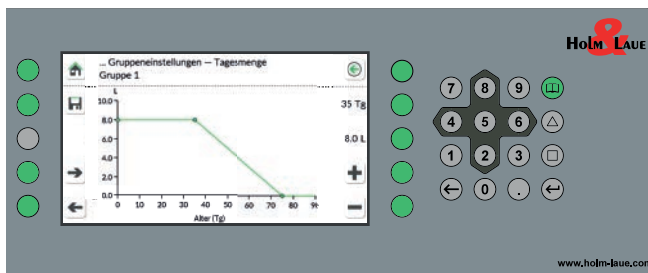

SmartKeys

By consciously doing without touch technology and using so-called SmartKeys, the CalfExpert can be operated reliably even in frosty conditions, in the rain, through gloves or even with dirty fingers. The illuminated SmartKeys guide you through the programme.

AmmoniaDetect

Ammonia irritates the mucous membranes of calves, even in small doses. This can lead to bronchitis in the long run, which can soon turn into pneumonia. Ammonia is only perceived as an odour when it is already in the harmful range. AmmoniaDetect is an electrochemical sensor that permanently measures ammonia levels in the barn air. It is installed directly in the lying area, protected from the calves by a pipe. CalfExpert analyses the measured values continuously and documents them in a chart. This enables you to optimise the ventilation of the calf barn and determine the best time for mucking out.

Automated work routines

With the CalfExpert, all employees know what they have to do and when. They carry out inspections, teat changes etc. at regular times. The CalfExpert generates empty messages for milk replacer powder, whole milk or cleaning agent in good time. And to avoid any stress, CalfExpert does not report "milk replacer powder empty" but already reminds you several hours beforehand.

CalfGuide app

CalfExpert comes with a Wi-Fi interface as standard. The CalfGuide app allows you to access important information directly on your mobile phone. This includes the general calf feeder data and details of the calf lists with the entire calf history. You can easily modify calf information and feeding curves in the app. In addition, CalfExpert sends messages about CMR fill levels or empty cleaning containers. A particularly practical feature is a HealthCheck, which allows you to objectively assess the health of your calves.

A feeder that has growing potential

With 4 feeder stalls, your CalfExpert is capable of feeding up to 100 calves, in certain circumstances even up to 150 calves! Even if you feed fewer animals today, our modular system allows you to expand the calf feeder machine at any subsequent time with all the options available. So you save money now but can still make use of all the possibilities later.

HYGIENE STATION



New **standard of hygiene** for calf feeders



Focus on the calf

So far we have learnt that the CalfExpert always mixes freshly, according to individual calf needs at the right temperature. It goes without saying that the CalfExpert cleans all tubes automatically as well. However: the place where the calf drinks the milk is woefully neglected where conventional calf feeders are used. This is the reason why many vets fear the transmission of illnesses at the teat. Here, the HygieneStation from Holm & Laue is setting THE new benchmark, not only in terms of hygiene but also by making work easier.



Save time with useful features. The learning function and the quick-release teat fastener make your work easier.



The animal weighing scales save feed costs through weight-controlled feeding, making it easier to monitor your calves.



Healthy calves through the highest standards of hygiene. Teat cleaning and tray rinsing guarantee low bacterial concentration.



Ideal calf health

Do you know where the highest germ count can be found in the calf box? Exactly! Where all the calves come to drink their milk several times a day. The HygieneStation now ensures cleanliness.

A clean teat at all times

With the new HygieneStation, the teat is cleaned from the outside with pressure and fresh water after every visit. Bacterial contamination on the teat accordingly drops by 80 %.



Cleaned saliva tray

Every calf produces saliva when drinking. With the HygieneStation this is collected together with the cleaning water of the teat in a mucus bowl and washed away after each feeding process. This means that the floor area within the feeding station stays clean and dry.

Natural drinking approach

The teat at the feeding station is positioned so that it slants downwards in a similar way to the teats on the suckler cow. This encourages the natural drinking position of the calf. When the head is stretched, this encourages the natural reflex of the oesophageal groove and reduces the risk of milk passing into the rumen.

LED teat lighting

Practice has shown that the calves can orientate better when the teat is illuminated. Milk consumption increases at night and the feeding processes are distributed more evenly over a 24-hour period.

Reduced workload

For many dairy farmers, a reduced workload is one big argument in favour of calf feeders. The new HygieneStation now makes the work that still has to be done significantly easier.

Calves teach themselves

As soon as a calf lifts the teat, a small amount of milk flows into its mouth. This stimulates the calf's initial drinking impulse; manual learning is necessary in only exceptional cases. Should manual learning still be necessary, milk can be pumped into the teat by pressing a key.

Can be tilted to clean

Many feeding stations are installed directly in the pens. The HygieneStation can be tipped forward at a 90° angle so that manure can be removed and the whole area can easily be cleaned with the use of a tractor.

Quick-release teat fastener

The teat can easily be changed in no time thanks to a quick-release fastener.

Milk pump valve

The possibility of triggering extra mixes at the CalfExpert is a great advantage if the milk can be run off conveniently straight into a bucket. At the milk pump valve you can decide whether a calf is to be fed in the station or the milk is to be pumped straight into a feeding bucket.





Control according to weight

All dairy farmers want their calves to gain plenty of weight. Yet weighing calves is strenuous and requires a lot of discipline. An animal weighing scale at the HygieneStation collects important information almost in passing.

Individual weaning

The CalfExpert records the daily growth of calves using the forefoot weighing scales. Calves that grow quickly can start feeding concentrate and hay at an early age and can thus be weaned off milk early on the basis of their individual weight development. This supports the development into a ruminant and saves money.

Better control

The animal weighing scales not only detect growing calves, they also register a decline in growth. This information is used to keep separate alert lists and helps identify sick calves at an early stage. Thus they can often be treated before the illness reaches a serious stage.



Weight information makes selection possible

At the end of rearing, you obtain valuable information about the development of each individual calf. This will help you make important decisions about which female calves should supplement your herd of dairy cows and which animals should be sold due to poor growth.

Please also read the technical article on this topic on page 90.

Useful features

When you are in the pen, during animal training for example, you often wish you could take a quick look at the feeder display. This wish has now been granted thanks to the new display on the HygieneStation.

HygieneStation display

Mounted directly on the HygieneStation or even on the wall, the HS display indicates relevant information about the calf in the calf group. The calf number is displayed in very large digits, making it very easy to read, even from a distance.

Credit and alarm status

At the push of a button you can also have the calf numbers of the credit or alert list displayed sequentially. This means it is no longer necessary to move constantly between the calf pen and the CalfExpert display. You can read off the remaining quantity conveniently and estimate how much longer the current visit is going to take. The alert status is also easy to recognise on the basis of a scale.

Lockable HygieneStation

There are calves that tend to suck one another. Although the entire functional principle of the CalfExpert and HygieneStation is designed to prevent this, it can sometimes be helpful to lock the animals in while they are feeding at the station so that they can feed in peace. The lockable door works pneumatically and needs a compressed air connection at the HygieneStation.





Options and features

CalfExpert basic configuration

- PowerMixer
- Milk freshly prepared on an individual basis for each animal
- CalfExpert feeding software with integrated operating instructions and help functions
- 7" graphic display with SmartKeys
- 8 feeding curves pre-set (including metabolic feeding curve), with adaptation possibilities for individual animals
- Rinsing of mixing tank and suction line
- Two detergent pumps for the automatic cleaning of all milk-carrying components with automatic empty message
- Wash temperature up to 65 °C
- Easy-to-clean surfaces made of stainless steel or plastic
- Powder store for 50 kg of CMR with only 112 cm filling height
- Powerful powder-conveying auger suitable for various CMRs
- Early empty warning for milk replacer powder
- Automatic registration of new calves
- Flextime feeding capabilities, to avoid stressful regular feeding hours
- QuickChange logic for faster credit changeover between the calves
- Up to 250 calves' data in memory
- Anti-freeze program that is activated automatically
- Fly shield supplied in the standard model
- Wi-Fi as standard in the calf feeder
- CalfGuide app

CalfExpert optional extras

- Second PowerMixer
- QuadroFlex (feed 4 calves simultaneously)
- Additional dosing unit
- Second powder chamber
- Powder chamber extension
- Whole milk diet option
- DoubleJug milk tank
- AmmoniaDetect

CalfExpert technical specifications*

Power supply and heating performance	400 V 16 A (6 kW) or 230 V 16 A (3 kW)
Capacity with 4 feeder stations	up to 100 calves (up to 150 calves in certain cases)
Identification system	Multireader HDX and FDX
Storage tank for milk replacer powder	90 l / 50 kg
Powder filling height	1.12 m
Boiler capacity	12 l
Dimensions of CalfExpert	0.6 x 0.7 x 1.21 m
Space requirement for CalfExpert	1 x 1 m

* Technical specifications subject to change





Comparison of the two HygieneStation models:

HygieneStation Standard



HygieneStation HeavyDuty

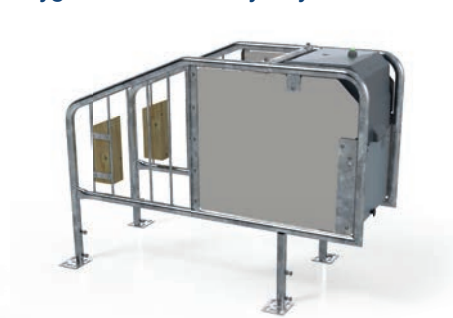

Typical field of application	Rearing dairy calves	Rearing calves for fattening
Dimensions (LxWxH)	1.31 x 0.47 x 1.00–1.15 m	1.54 x 0.60 x 1.10-1.25 m
Interior width	27–36 cm	37-50 cm
Number of stations per CalfExpert	Four	Four
Animal recognition via H&L collars or ISO ear tags	Half and full duplex	Half and full duplex
Anti-pirate milk valve to prevent milk theft	yes	yes
Quick-release teat fastener	yes	yes
Milk transport to the teat	yes	yes
Learning aid (milk to mouth)	Automatic and manual	Manual only
Standing distance to the CalfExpert feeder	Up to 7 m	Up to 7 m
Height adjustable	yes	yes
LED teat lighting	yes	no
Temperature sensor for frost protection	yes	yes
Teat rinsing	Optional extras	Standard option
QuadroFlex (4 calves can feed)	Optional extras	Optional extras
HygieneStation display	Optional extras	Optional extras
Saliva tray	yes	no
Can be folded away when mucking out	yes	no
Tilt safety device	Optional extras	Not required
Animal weighing scales	Optional extras	no
Lockable station	Optional extras	no
Milk pump valve	Optional extras	no
Weight fully equipped	Approx. 50 kg	Approx. 90 kg

WholeMilk⁺ Plus



State-of-the-art whole
milk feeding for calf
feeders



Intelligent whole milk feeding on the CalfExpert

Whole milk feeding is becoming increasingly important in calf rearing because calves develop very well with natural whole milk. In addition, feeding whole milk from the farm means conserving valuable resources.

However, there are a few technical things to consider when feeding from the calf feeder. The milk must be cooled during storage on the CalfExpert to keep it fresh. Furthermore, the hygiene and cleaning of the storage tanks and the milk line are very important. There has to be a constant supply of milk in the storage tank because the calves come to feed all day long. But if the calves feed more than usual, the tank is empty too quickly and the animals do not get any milk for a certain time. On the other hand, it often happens that there are still residual quantities in the tank when it is due to be cleaned and then refilled. This is then often discarded.

Finally, dairy farms have different operations that require the feeder to be prepared for all whole milk scenarios.

But this is no problem for the CalfExpert. The next few pages explain how it has become the best whole milk processor on the market.



Flexible whole milk feeding and storage options to suit any farm.



Optimum use of whole milk resources thanks to intelligent control.



Healthy, contented calves thanks to unrestricted access to fresh whole milk.



Feeding high-quality whole milk intelligently

Whole milk is digested perfectly by the calf and results in the best performance. With the CalfExpert whole milk programme you can set whole milk proportions or supplement the whole milk in the feeding programme flexibly.

Flexible whole milk programmes

The CalfExpert feed curves not only enable the amount of milk and the concentration of milk replacer to be set, but also allow the proportions of whole milk to be adjusted according to age. This permits a gradual transition from whole milk components, meaning calves can slowly become accustomed to the change in feed.

WholeMilkSmart

This option on the CalfExpert is a fill level sensor that can determine the fill level of the connected milk tank based on the pressure in the milk line.

CalfExpert can predict how long the milk supply will last by taking into account the calves' expected consumption. The corresponding menu then shows the minimum amount of milk that needs to be refilled the next time you are in the barn (in the example: at least 24 l at 6:00 pm).

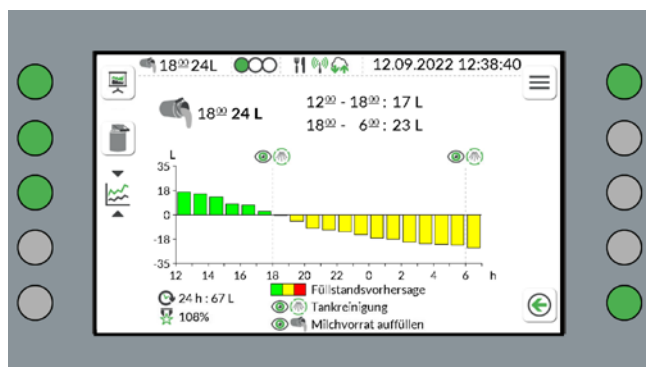

This overview is also available in CalfExpert without WholeMilkSmart, but the amount of milk must then be entered manually.

EvenMilk: feeding whole milk intelligently

What happens with your calf feeder if the supply of whole milk is insufficient and is used up prematurely? Does it then use powdered milk as a substitute? This causes changeover stress with your calves and is likely to cause digestion problems. The "EvenMilk" option provides information on the amount of milk available and the expected quantity to be consumed to ensure that the missing quantities of whole milk are supplemented evenly using milk replacer feed. A uniform ratio of the two feeds is calculated and fed over the course of the day.

The whole thing is also done while taking into account the different needs of young and older calves. Younger calves, for example, prefer to receive whole milk, while older animals already receive higher proportions of milk replacer.

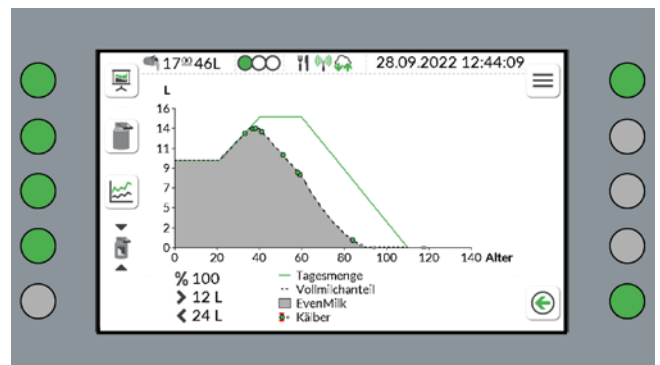



Storing whole milk in traditional milk tanks

There are different ways of storing and dispensing milk, depending on the size of the farm and how work is organised. However, it is always necessary to ensure that the tanks and all milk lines are adequately cleaned. As the CalfExpert feeds 24 hours a day, it is important to avoid long waiting times caused by cleaning. For this reason, there are various solutions on the CalfExpert for different whole milk scenarios.

A simple milk tank on the calf feeder

A simple cooling tank directly on the CalfExpert needs to be filled manually. The downside of this system is that the actual fill level of the tank is unknown before the tank is filled. Residual amounts may have to be discarded. In addition, conventional milk tanks do not switch off refrigeration when the fill level is low, so that any residual milk may freeze. These tanks are cleaned manually. The CalfExpert has a cleaning programme for the supply line to the CalfExpert that needs to be started manually.

This is where the **WholeMilkSmart option** helps you, because you can see in the CalfGuide app how much milk is left in the tank and when it would be time to wash and then refill the tank.

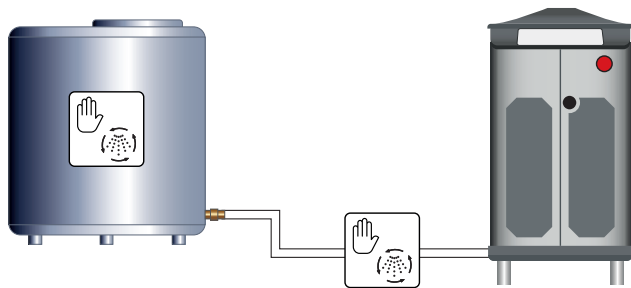

A simple milk tank with automatic supply line cleaning (SmartWash Undock)

The manual cleaning of the supply line described above is often forgotten or neglected due to time constraints. However, the supply line of the CalfExpert's whole milk supply is a particularly sensitive area from a hygiene point of view. With the **SmartWash Undock** solution, a cleaning line is routed to the milk tank connection, where there is a switching valve that can be controlled via programmable connections on the CalfExpert.

The CalfExpert disconnects from the milk tank by means of this switching valve and washes the supply hose during normal machine cleaning.

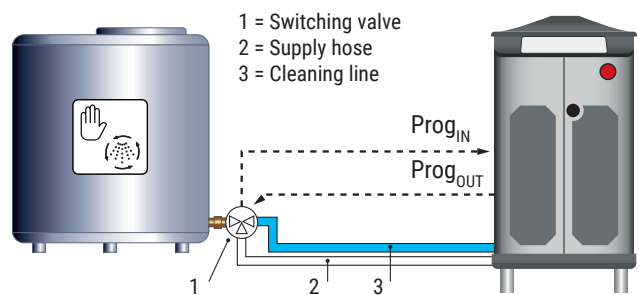

One milk tank with an automatic cleaning cycle (SmartWash)

Conventional tanks can be equipped with a cleaning pipe and a cleaning spray head in order to clean them optimally. With **SmartWash**, the milk tank and the supply hose are cleaned by the CalfExpert via a cleaning line. If the CalfExpert detects that the tank is empty, it will start its cleaning programme, performing a combined cleaning cycle of tank and system. This results in the tank, supply hose, mixer, internal system and milk hoses to the HygieneStations being cleaned in a single "wash". The milk tank needs to have an automatic cooling shut-off so that it does not operate during cleaning. The CalfExpert offers an option of a programmable digital output for this purpose, which can send a corresponding signal to the milk tank (tank modification by an electrician is required).

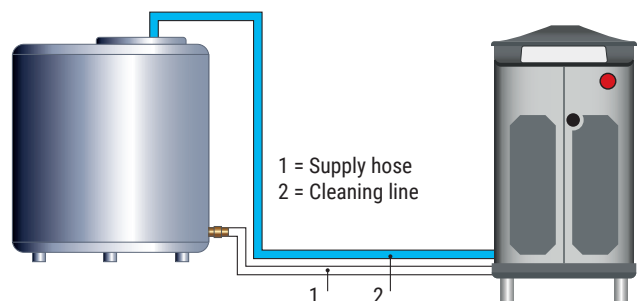



Whole milk supply via ring line systems with central storage

Ring line systems are often used in larger operations that are equipped with several calf feeders and possibly even continuous pasteurisers for whole milk. The milk is transported from a central milk parlour with a storage tank to the CalfExpert feeders via supply lines.

Ring line system with manual cleaning

Ring line systems need to be cleaned regularly. The CalfExpert may not feed when cleaning is in progress to prevent the calves from drinking the cleaning solution.

This requires communication between the ring line and CalfExpert.

Programmable digital inputs and outputs on the CalfExpert

The CalfExpert receives a 24 V signal from the milk line cleaning control at the programmable digital input. This informs the feeder when the line is being cleaned and interrupts the feeding to start internal cleaning itself (if you wish). This avoids further interruptions to feeding. The increased pressure in the milk line can under certain circumstances open the valves in the CalfExpert and thus cause malfunctions. A fast-switching valve at the connection of the supply line to the calf feeder must prevent this. The programmable digital output allows the CalfExpert to open this valve when it needs milk for feeding. The drawback of this system is that the supply hose to the CalfExpert must be cleaned manually with the assistance of the CalfExpert.

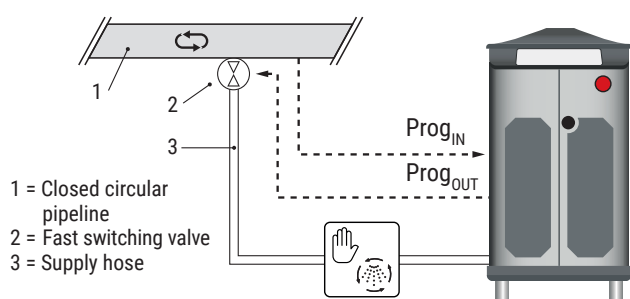

Ring line system with automatic Undock cleaning

Manual cleaning of the supply hose is often forgotten or deliberately skipped in order to save time and give the calves more time to feed. However, this has serious consequences for hygiene and hence for the health of the calves.

Programmable digital inputs and outputs on the CalfExpert with Undock cleaning

As with the SmartWash Undock solution on the milk tank, this solution allows a cleaning line to be attached to the supply line connection valve. An additional switching valve provides the necessary cleaning circuit. It is controlled by digital inputs and outputs on the CalfExpert.

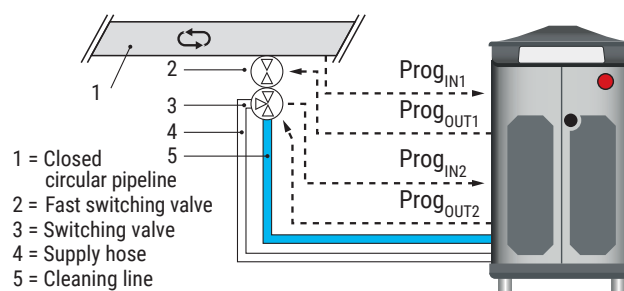

Ring line system with integrated cleaning

If the ring line cleaning system has a programmable control, the CalfExpert can also coordinate its own cleaning with the cleaning of the line.

Coded digital inputs and outputs on the CalfExpert

By using two digital inputs, the ring line can send up to 4 different status signals (e.g. rinse, clean, milk present, empty). The CalfExpert can then join the cleaning process and takes rinsing and cleaning fluid from the ring line for its own cleaning. This also cleans the supply hose automatically.

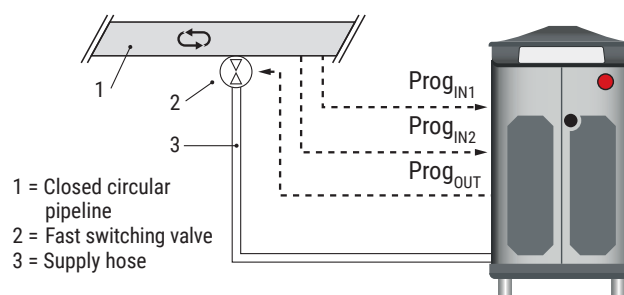



DoubleJug – unique in whole milk storage

The DoubleJug is a milk tank that has been designed especially for automatic calf feeders. Since there are two tanks integrated in one unit, milk is always available and optimum hygiene is guaranteed.

24 hours whole milk feeding

The CalfExpert calf feeder draws its milk from one of the tanks. Should this tank become empty, the DoubleJug switches automatically to the second tank and the CalfExpert can continue to feed without interruption. This means no waiting times and no interruptions in feeding, thus making ideal use of the high performance of the CalfExpert.

Controlling the DoubleJug via the CalfExpert

The DoubleJug is controlled via the CalfExpert and programmed at the feeder display. This allows the tank status to be viewed directly at the feeder as well as in CalfGuide at any time. An information unit can be fitted to the DoubleJug as an option that displays the most important information such as temperature, fill level etc. directly in the barn.

Automatic cleaning

As soon as the first tank is empty, it is cleaned automatically. This means maximum hygiene and best milk quality. The cleaning cycles are coordinated by direct communication with the CalfExpert. Thus the daily cleaning of the milk line between the DoubleJug and the CalfExpert only takes place when the milk tank itself is being cleaned. This minimises any waiting times for the calves.

Two CalfExperts share one DoubleJug

Two CalfExperts can draw milk from one DoubleJug if the two feeders are close enough to the DoubleJug (a maximum of 6 metres). When one of the DoubleJug's tanks is empty, one of the calf feeders takes over the joint cleaning of the CalfExpert, tank and supply line. The other feeder performs internal cleaning during this time. The next time the second tank is empty, the second CalfExpert takes over cleaning. Coordination is effected via CAN bus communication lines.

Refilling whenever convenient

Once a tank has been cleaned, DoubleJug is ready for filling. The advantage of the two-chamber system is that the DoubleJug can be filled at any time without having to wait for the exact moment the milk tank is empty. There are neither residual quantities nor times during which the CalfExpert stops feeding due to lack of milk.

Cool stuff

The DoubleJug is equipped with a cooling unit for both tanks. Even small amounts of milk are cooled efficiently without freezing.

Characteristics

- AutoFill function: when a tank is empty and clean after automatic cleaning, it can be automatically refilled by a suitable continuous pasteuriser.
- AutoEmpty function: when one tank is empty, DoubleJug automatically switches to the full tank. The empty tank is then cleaned together as part of the cleaning cycle of the CalfExpert.
- Fast cooling to reduce bacteria growth in the insulated tank.
- Ideal for the CalfExpert, but can also be used with other calf feeders.
- Automatic washing program based on the CIP system.
- Digital control of the tank through the CalfExpert including combined cleaning of CalfExpert and DoubleJug.

DoubleJug technical specifications *

Power supply	400 V, 16 Amp
Water supply	Hot and cold water
Drain	Floor drain necessary
Required air pressure	5.5 to 7.5 bar
Dimensions 2 x 190 l	1.63 x 0.87 x 1.16 m
Dimensions 2 x 380 l	1.63 x 0.87 x 1.55 m
Space requirement	2 x 1 m

* Technical specifications subject to change

CALFQ Guide



Practical **management software** for modern calf rearing



All calf data at a glance

Wouldn't it be nice if you could access all the information about your calves at your PC or on mobile devices at any time? And what about networking all the devices you use in rearing such as CalfExpert calf feeders, MilkTaxis and CalfControl animal weighing scales so that they automatically exchange data and complement each other? And if your employees could then see the alert lists on their own smartphones or tablets and could work through tasks, all the workflows in the calf barn would be clearly defined. How would you feel about that? This is all possible using CalfGuide, your central data and management system for calf rearing. The central CalfGuide server collects all the data from all of your feeders, MilkTaxis or WeightControl animal weighing scales and makes them available to you in a clearly structured form.

With the new CalfGuide you can also control and configure all devices centrally. And a practical export interface provides other herd management programs with the most important data after rearing has been completed. Thus CalfGuide is the interface between the rearing management of your calves through to their further development into high-performance cows.



Never miss a thing thanks to smart data management for all mobile devices.



A comprehensive data pool allows performance monitoring and provides analysis options.



Healthy animals through networking of all devices and early alerts.



Current calf data

CalfGuide gives you a complete overview of all calf feeders and all calves on your farm.

Calf management

Taking clear lists as the starting point, you navigate directly to the feeding and growth curve of individual calves. A calendar function enables you to track past incidents and plan future tasks. This makes it easy to have a good overview or analyse individual animals in great detail.

Health index

CalfGuide calculates an alarm index on the basis of a wide range of data such as feeding consumption, drinking speed, visiting frequency, weight development etc. This allows you and your employees to see immediately which of the calves need your attention first. In addition, abnormalities such as illness can be recorded in an "event diary" and are thus clearly documented.

Archive

CalfGuide doesn't forget anything. After your calves have been weaned, all data such as feeding quantities, weight development, treatments etc. are saved permanently in an archive. In other words, CalfGuide allows you to see – even years later – how you fed your best cows when they were just calves. This helps you to optimise your feeding programs in the long term.

Support tools

All employees know what they have to do and when, and you can keep an eye on all the working steps and development of your calves at all times. Urgent tasks are displayed immediately.

Bidirectional control

Important calf data can be adapted and configured directly in the CalfGuide program. These include e.g. age, group assignment, feeding curves, individual changes in feeding plans and much more besides. Once the configurations have been set, they are automatically transferred to the CalfExpert or Milk-Taxi.

Task manager

CalfGuide organises your work and reminds you what is to be done. Move to a new stall after xxx days? Separate the male calves after xxx days? You simply define all recurring tasks once in the form of events or to-do lists, and CalfGuide will remind you and your employees every day of what needs to be done.

Technical fault messages

CalfGuide shows you all the technical fault messages concerning your calf feeder, even the ones CalfGuide has resolved itself. Empty messages for cleaning agents or an early warning system for a low whole milk or CMR level at the CalfExpert are sent via the CalfGuide system.

Pasteurising log

Pasteurising is a particularly sensitive process because the quality of the milk can suffer if there are temperature problems during the process. You are on the safe side with CalfGuide, because it always records the precise temperature curve for you and indicates whether there were any inconsistencies.



Cross-system networking

Anyone can be excused for losing track in this "big data" era. And your calves do indeed generate a huge amount of data in the CalfGuide network. CalfGuide processes this flood of data so that you can concentrate on the most important information.

LAN/Wi-Fi - tablet or PC

The data from your automatic feeders are recorded and managed centrally on a server. The CalfGuide system then provides a Wi-Fi connection in the calf barn so that you can use all the functions at any time e.g. with a PC tablet. It goes without saying that you can integrate CalfGuide in your farm network, allowing you to use all the CalfGuide functions from your office. The optional connection of the CalfGuide system to the internet even permits external access via the CalfGuide Cloud.

CalfGuide app

A limited selection of information can be accessed directly on your mobile phone using the CalfGuide app. This includes the box list with details for the MilkTaxi or details about the calf lists on the CalfExpert. In addition, messages can be received and tasks requested from the calf feeder events or ToDos.

With CalfExpert, this also works without CalfGuide, directly via the calf feeder's Wi-Fi interface.

CalfGuide Cloud

With the CalfGuide Cloud you can access your CalfGuide server via the internet. This allows you to access your data and information from anywhere in the world or permit service technicians to take a look at the technology if any problems should occur.

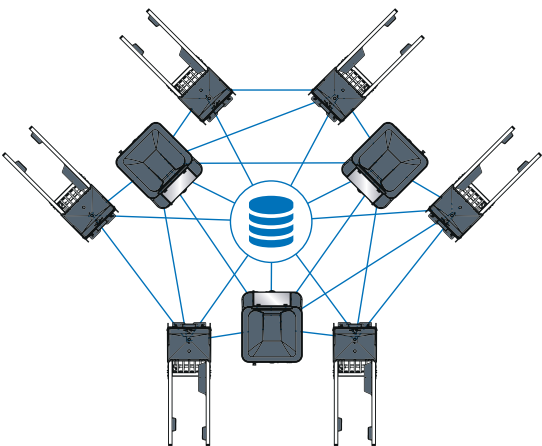

Milk  TAXI



More than a mobile milk tank: **individual feeding** and optimum hygiene



New bucket feeding methods

In 2005, Holm & Laue revolutionised bucket feeding with the invention of the MilkTaxi. It put an end to hauling buckets around and ensured that every calf received an optimum mix at just the right temperature. Today, helpful extras such as the electrical drive, the wireless-controlled dosing pump, the possibility of pasteurising and cooling, the hot water heater and the drenching probe for cows have made the MilkTaxi an indispensable tool for modern dairy farms. The latest generation 4.0 has revolutionised bucket feeding yet again. Now, the MilkTaxi permits reliable feeding and weaning depending on calf age – which was only possible with a calf feeder before. It recognises every igloo and calculates the correct current feeding quantity for the calf! This means the MilkTaxi recognises the milk quantity required for the next feed and prepares the mixture step by step, including supplementing through whole milk! This way, faults or carelessness are no longer possible. And the highlight is that all the feeding data can be saved permanently and retrieved at any time via tablet or PC. This allows feeding faults to be localised and eliminated immediately.

Read the following pages to find out which options for the MilkTaxi 4.0 are important for you and how you can reap the benefits.



Bucket feeding made easy: feed calves conveniently and quickly, making work enjoyable.



Resource-saving feed costs thanks to pasteurisation of whole milk and use of individual feeding curves.



Precise feed preparation ensures balanced feed and healthy calves. Efficient tank and bucket cleaning ensure optimum hygiene.



Simpler preparation

Many of the strengths of the MilkTaxi are not immediately obvious: how it mixes milk replacer powder lump-free in seconds or gently heats whole milk without it burning surprises everyone who sees the MilkTaxi for the first time.

Powerful base-mounted agitator

The 250 Watt agitator mixes any milk replacer lump-free in seconds. In addition, the agitator supports the heater through short mixing intervals. **IMPORTANT:** these intervals are adapted to the milk quantity. Its location in the base guarantees maximum working safety and means nothing gets in the way during tank cleaning.



Gentle heater

The MilkTaxi works with a surface heater over the entire base area. Unlike with spiral heaters, this prevents the occurrence of "hotspots" where milk can burn and stick. Thus the milk is heated quickly yet its quality is retained. The display always informs you of the current temperature of your feed.

Time control

Many functions such as heating and pasteurising can be programmed using a digital timer. The intelligent cooling programme only cools when the tank actually contains liquid which has too high a temperature, and stops cooling in good time before heating in order to save energy costs.

SmartMix

Up to now, there were a lot of potential mistakes to be made during preparation. That is now passé, because the new MilkTaxi guides you step by step to the perfect mixture.

Mixing calculator calf milk replacer

From now on, you define the required CMR concentration (percentage of dry matter content) and your scoop size just once. Then you fill the MilkTaxi up to the required feed quantity. Smart-Mix adds the necessary weight of the CMR automatically and tells you how many scoops of the CMR you need. Even the solubility of the CMR is taken into account, because 20 kg of CMR dissolved in 100 l water is less than 120 l milk (namely 114 l). The MilkTaxi 4.0 automatically corrects this error.

Exact filling level display

The MilkTaxi automatically recognises how much milk or water has already been filled into the tank and shows the current fill quantity constantly on the display.

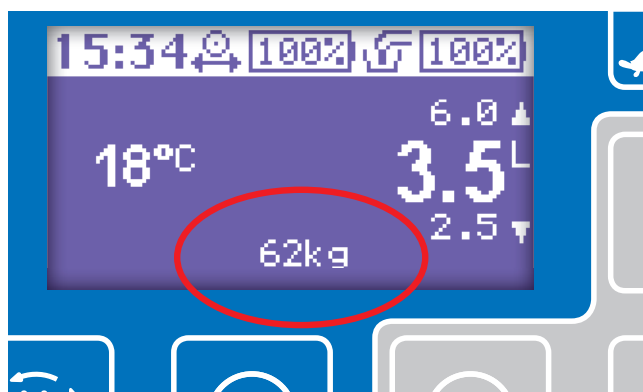

Whole milk supplement with calf milk replacer

And if whole milk and CMR are to be mixed? What if your milk has a dry matter value of 12.3% but you need an overall mix with 13.5% dry matter? Then SmartMix recognises how much whole milk has been filled and determines how much water and CMR have to be added to get the required milk quantity in the required concentration.



Better feeding

The saved feed quantities, the remote control with the tubing up to 10 m long and the drip-free dispensing make feeding child's play.

Simple dispensing

With 9 freely programmable dosing levels you can dispense almost any feed quantity – without any annoying dripping. In addition, the handle has been ergonomically adapted and is nice and light. Thanks to the integrated battery, you are independent of the power supply near the calves. This leaves you completely flexible in your choice of positioning of individual igloos and allows you to feed calves in different places.

Wireless remote control

With the remote control on the dispensing arm you can conveniently feed even the calves that are up to 10 m away from the MilkTaxi without needing a cable. It goes without saying that the quantities can be adapted individually at the dispensing arm in this case too.



Statistics function

You can check the most important work steps in the MilkTaxi's display menu using a special statistics function. Every pasteurising cycle, every feeding and every cleaning is documented. This information is still available even weeks later through a calendar function, allowing you to check the workflows on your farm perfectly.

SmartID

During feeding you keep asking yourself how old this particular calf is and how much milk it should be getting. This is no longer necessary, because the MilkTaxi recognises every pen and the calf's age.

Wireless detection of the calf pens

The MilkTaxi detects each pen wirelessly as it moves past and the pen number is shown on the display. The operator now selects the right amount of feed for the calf or group of calves, presses the release button, which causes the milk to be filled into the buckets. The weight fed is registered and stored for each pen.

Intelligent pen management

Smart-ID works both for single and group pens. For groups of calves, it indicates how many calves are in the group and whether they are fed using individual buckets or "teat bars". When used in conjunction with the CalfGuide management application, information can be stored for individual pens and automatically retrieved at the next feeding. This is how staff members are alerted to sick animals or other unusual circumstances. An enormous improvement in work quality, particularly where there are changes in staff.

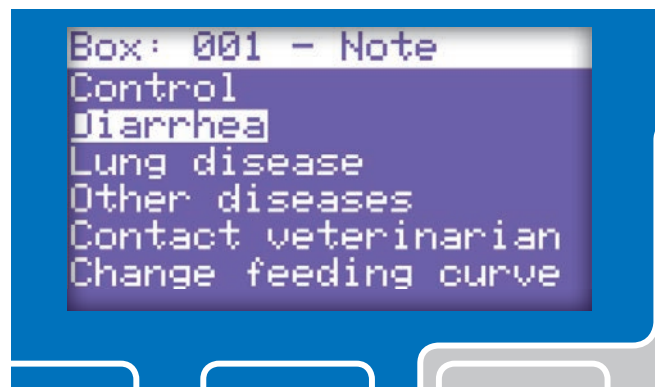



Easier transportation

Easy milk transportation has been THE great help for our customers for more than 10 years now.

Stable 4-wheel undercarriage

The MilkTaxi is extremely stable on 4 wheels with a low centre of gravity. It does not topple over even when moved quickly, over uneven terrain and full. Thanks to the 40 cm front wheels and the large ground clearance, unevenness or small thresholds are not a problem. The 260 l model is also available as a single-axle trailer as an alternative.

EL-AN electrical drive

You can move all models forwards and backwards at two different speeds using the stepless electrical drive. This not only makes calf feeding fun, but it also goes easy on your back.

HeavyGrip

The new, well-gripped tyres for the MilkTaxi provide grip on slippery surfaces or steep terrain. Almost better than driving a tractor!



Failsafe tyres

They're unbreakable! No nasty surprises with flat tyres. The elastic filling of the wheels offers the best conditions for stony tracks.

Pasteurising

Mastitis bacteria play an important role in illnesses in the calf pen too. Pasteurising eliminates up to 99.5% of these bacteria and is already part of the calf feeding standard on many dairy farms.

Pasteuriser

During pasteurising using the so-called batch method, dangerous pathogens are destroyed to 99.5% at a temperature of 63 °C over 35 minutes. As an alternative to this program, the MilkTaxi offers two different heat treatment methods at 60 °C over 60 or 70 minutes. All the starting times can be freely programmed. The result is that the milk has already been pasteurised when you arrive in the barn for feeding in the morning.

Automatic cooling function

With the MilkTaxi pasteuriser water cooling is part of the standard package. This allows the milk to be stored fresh until feeding or pasteurising. The automatic cooling programs are particularly practical when robotic milkers are used. It records the fill level and temperature for automatic filling. In addition, the cooling process is programmed in such a way that it makes optimum use of the required energy.

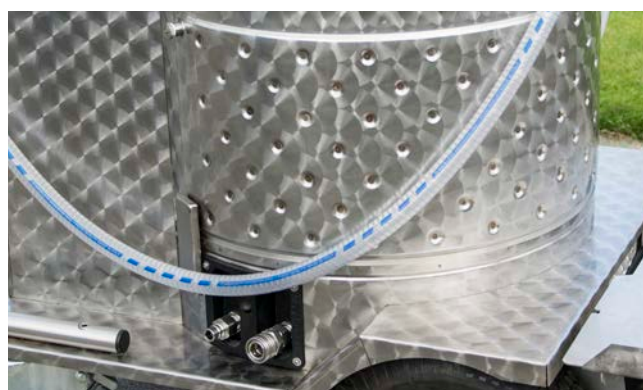

Hot water heater

If you want to cut costs on energy and if you have plenty of hot water, then an optional hot water heater saves expensive energy costs otherwise incurred for heating the milk.



Comfortable work

At the end of the day, it is the convenience that makes your work easier. From user-friendly display and easy cleaning to applications beyond calf feeding: you won't want to be without your MilkTaxi.

Glove compartment – for small and large aids

This practical storage box offers space for all the small tools needed in the calf pen. Everything has its place in the practical glove compartment, whether ear tag pliers, thermometer, weight tape measure, disposable gloves, barn lists or other important items. What is more, the level cover serves as an excellent writing surface. All these things are quickly at hand in other places because the entire box can be detached from the MilkTaxi and transported very easily.

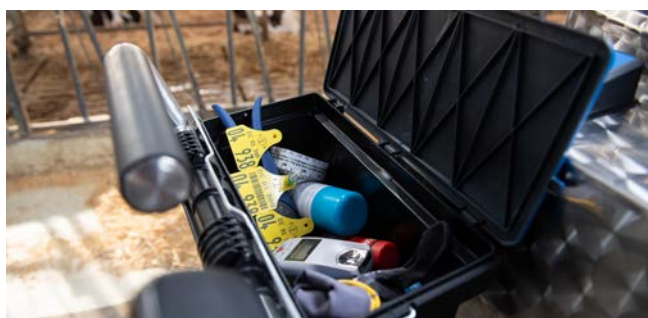

Bucket transport

The hinged frame, allowing you to transport up to two milk churns, is particularly practical. It can also be used for moving other things such as dry feed or tools. The 8 l colostrum jugs are particularly practical. Inserted in the larger churn with hot water, the milk remains at the perfect temperature before it is fed to the calves.



Cleaning and hygiene

FlushMaster bucket cleaning

Cleaning feed buckets is time-consuming, as you have to collect the buckets and take them to the washing area. The FlushMaster allows you to clean the buckets using a rotating nozzle in the MilkTaxi, directly at the calf pen. The FlushMaster is also ideal for thorough tank cleaning, leaving a clean interior from cover to base. This practical aid can be retrofitted to all MilkTaxi models with a pump.

Automatic cleaning

Since the cover can be fully opened, cleaning of the tank is extremely easy. The semi-automatic cleaning program guarantees optimum hygiene. Residual quantities can be emptied completely, even from the pump and hose. Supplementary cleaning with a brush improves the result, and your MilkTaxi is ready to go again after just a few minutes.



FoodSafe.

Do you sell some of your milk directly? The FoodSafe edition of your MilkTaxi is also suitable for transporting food, enabling you to transport your milk easily and hygienically from the milk tank to the milk filling station. All components used comply with the specifications of the German Food, Commodities and Feed Code (according to VDE Prüf- und Zertifizierungsinstitut GmbH).



Perfectly illuminated

It is often pretty dark in the early morning hours or in the winter months. Nevertheless, the MilkTaxi will make light work for you.

Lights off – spotlight on

The SpotLight mounted on top of the MilkTaxi brings light into the darkness: the completely flexible gooseneck provides a 360° all-round view at working height.



Dark? No problem

Thanks to the integrated LED drive light you always see where you are going. So feeding calves in more remote calf hutches in the evening is no problem.



Useful accessories

And there are even more special options for the Holm & Laue MilkTaxi: for example, a jacket or drenching set.

MilkTaxi jacket

Calf milk can cool down between warming and feeding on particularly cold days. Our new jacket for the MilkTaxi keeps it warm for about twice as long as without the jacket, according to our own trials (in the trial at -13°C , the milk lost about 1°C after 8 minutes without the jacket, but only after about 17 minutes with the jacket).



Drenching cows

A cow drenching option is also available. The drenching fluid can be ideally mixed and temperature-controlled in the MilkTaxi, transported to the cows and then gently drenched into the rumen via the pump. Rather than struggling with a manual pump, you can focus completely on the cow thanks to the MilkTaxi.





MilkTaxi 400 Litres

The large trailer model for up to 100 calves or 800 litres of feed per day (2 x 400l).

Would you like a little more?

Sometimes even the largest MilkTaxi to date with 260 l is not enough. This is not only because farms are getting bigger, but also because more milk is being fed per calf. The 400 litre MilkTaxi now also offers larger farms virtually all the advantages that the tried and tested smaller models have. Even the pasteurisation function is available as an option, leaving nothing to be desired with the 400 model.



Made for rugged surroundings

The MTX 400 is built particularly sturdily not only because of its higher payload. The spring-loaded axle ensures that the transport of milk to the calves is steady and smooth, especially on uneven tracks.



MilkTaxi Dosing Unit

Do you already have a mobile milk tank and would like to use it as a "MilkTaxi"? The MilkTaxi's dosing unit makes this possible.

MilkTaxi XXL

If the tried and tested MilkTaxi models are not large enough, the dosing unit offers an ideal opportunity to convert existing milk tanks into an XXL MilkTaxi. The dosing unit consists of the battery-operated pump with dispensing arm. Display and control element are conveniently integrated in a separate unit in the driver's cab.



Temperature and fill level measurement

The dosing unit also measures the milk temperature and determines the fill quantity in the tank by means of the integrated SmartMix sensor. This means that all sizes of farm can benefit from the advantages of precise dosing and optimum temperature control when feeding their calves. Turn your tank into a MilkTaxi XXL!





Options and features

MilkTaxi basic configuration

- MilkTaxi model version 100 l, 150 l and 260 l with stable and manoeuvrable chassis on 4 wheels; front tyres 40 cm
- Electronic control with liquid level sensor, thermometer and statistics function
- Powerful base-mounted agitator mixing at regular intervals in heating mode
- MilkTaxi, model version 260 l and 400 l, built as a trailer with jack wheel
- Tank made of easy-to-clean, polished stainless steel
- Lockable lid with sealing ring; opens to full radius
- 1 ¼" drain tap for complete draining
- LED headlight
- Semi-automatic cleaning program

MilkTaxi pasteuriser basic configuration

- MilkTaxi model version 100 l, 150 l and 260 l with stable and manoeuvrable chassis on 4 wheels; front tyres 40 cm
- Electronic control with liquid level sensor, thermometer and statistics function
- MilkTaxi, model version 260 l and 400 l, built as a trailer with jack wheel
- Tank made of easy-to-clean, polished stainless steel
- Lockable lid with sealing ring; opens to full radius
- 1 ¼" drain tap for complete draining
- LED headlight
- Semi-automatic cleaning program
- Pumping, mixing, heating as standard
- Up to 6 programmable pasteurising start-up times
- Integrated water cooling
- Three selectable programs: 65 °C for 35 minutes, 60 °C for 60 minutes, 60 °C for 70 minutes

MilkTaxi options

- Floor heating (3 kW, 5 kW, 6 kW or 9,7 kW)
- Pump with dispensing arm
- Wireless remote control dispensing arm
- EL-AN electrical drive
- HeavyGrip tyres
- Failsafe tyres
- Smart-Mix
- Smart-ID
- Tilt-up churn support frame for two 30 l milk churns
- Colostrum jug
- SpotLight
- FlushMaster
- Glove compartment
- Cow drenching function
- FoodSafe food approval
- MilkTaxi jacket
- CalfGuide for MilkTaxi

MilkTaxi pasteuriser options

- Wireless remote control dispensing arm
- EL-AN electrical drive
- HeavyGrip tyres
- Failsafe tyres
- Smart-Mix
- Smart-ID
- Tilt-up churn support frame for two 30 l milk churns
- Colostrum jug
- SpotLight
- FlushMaster
- Glove compartment
- Cow drenching function
- FoodSafe food approval
- MilkTaxi jacket
- CalfGuide for MilkTaxi
- Hot water heating



MilkTaxi technical specifications*

	Useful tank capacity	Total tank capacity	Width (cm)	Length (cm)	Height (cm)	Power supply	Pump performance	Heating power	Agitator	Tyre size
MilkTaxi 100 l	100 l	115 l	60	126	109	230V / 16A	Approx. 40 l/min	3 kW	250 W	400 / 265 mm
MilkTaxi 150 l	150 l	180 l	75	129	109	400V / 16A	Approx. 40 l/min	5 kW	250 W	400 / 265 mm
MilkTaxi 260 l	260 l	290 l	76	133	119	400V / 16A	Approx. 40 l/min	6 kW	250 W	400 / 265 mm
MilkTaxi trailer	260 l	290 l	120	140	125	400V / 16A	Approx. 40 l/min	6 kW	250 W	400 mm
MilkTaxi 400 l	400 l	480 l	130	220	140	400V / 16A	Approx. 40 l/min	9.7 kW	250 W	570 mm

* Technical specifications subject to change



WEIGHT CONTROL



Flexible **weight**
measurement



Intelligent calf weighing scales with supporting management software

WeightControl are electronic weighing scales for calves that not only determine the weight of the animals, but also store other important data. Holm & Laue livestock weighing scales are available as platform scales, mobile individual scales and group scales for front loader transport. In addition, an RFID reader automatically recognises the calf's ear tags, and you can enter further information at the operating terminal.

With WeightControl, you no longer leave anything to chance and always have an eye on how your calves are developing. You can now make important decisions about feeding strategies or animal selection based on facts, not just on gut instinct. Please also read our technical article on 90.

The different WeightControl models offer every farm the right solution for determining animal weights and documenting the key data. This allows you and your team to manage at the cutting edge.



Intelligent weighing scales: capture weights and data and analyse them in the CalfGuide management system.



Available in three different models – suitable for every farm.



Data-driven decisions help to rear healthy and thriving calves.



Electronic calf weighing scales – suitable for any farm

The new calf weighing scales make recording weight and other information child's play. The system is based on three different types of animal weighing scales, each with electronic animal recognition and an additional input terminal, where relevant data can be entered very easily.

WeightControl "Base" – The stationary platform scales

The WeightControl Base is intended to be driven on with small transporters or carts for calves (e.g. the CalfBuggy see p. 80). Every time a calf is transported, you just drive over the weighing scales and record the current weight in no time. Ramps make the whole process even easier. The platform weighing scales are also suitable for other purposes. They can handle loads of up to 2,000 kg, so that feedstuffs or other items can also be weighed.



WeightControl "Single" – The mobile pass-through weighing scales

WeightControl Single can be transported wherever calves are to be weighed. The doors can be mounted so that they are hinged on the left or right. This allows calves to be easily led in and out of the weighing scales – depending on site conditions. Battery operation allows use even in remote locations, such as outdoor calf hutches.

WeightControl "Multi" – The transport group box

WeightControl Multi is ideal if the calves not only need to be weighed, but also transported. Up to 5 calves (depending on size) can be easily transported in the box with the help of a front loader pick-up (e.g. from individual hutches to the group pen or after weaning to the young cattle pen). The box does not even have to be set down for weighing. You can therefore round up your calves directly in the straw pen and determine their weight.



Calves can enter the weighing scales through doors on three different sides, the hinged side of which you can also specify individually. With this flexibility, you can drive through the rows of calf pens and collect the calves on the left and right. It's all done quickly and safely.





Unbeatable features

Additional WeightControl functions simplify your operations on the farm.

Provisional calf numbers

Calf weighing should be properly integrated into your farm routine. But it's not always possible to plan everything. When, for example, a calf is born at night, your colleagues on the night shift can weigh it directly and take it to the calf hutch. All this before the calf has been given its ear tags. In this case, WeightControl allows for "temporary calf numbers" to be assigned to the calf. It then receives a temporary neck strap first. The next day, the herd manager can attach the permanent ear tag, add this information to the software later and remove the temporary neck strap.

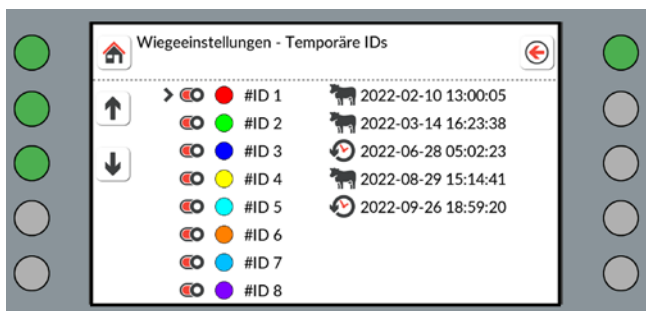

Add-on weighing function

Each additional calf entering the group weighing scales is weighed and its individual weight is recorded. You can use the transponder reader to read the electronic ear tag or quickly enter the number yourself at the terminal. WeightControl recognises from the registered weight whether the calf is still on the weighing scales and can even determine which group pen the calf has been released into because the known weight has now left the scales.

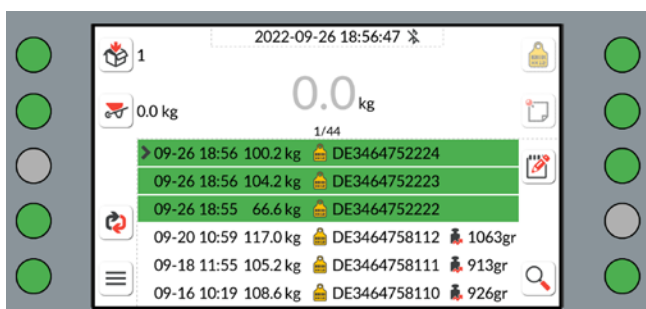

Monitoring days

Many farms organise their tasks into weekly routines. If, for example, you always move calves that are at least 3 weeks old on Wednesdays, then this is also an ideal time to weigh the calves because you are transporting them anyway. But then, of course, not all calves are the same age and a uniform reference weight on a certain cut-off date, e.g. the 21st day of life, is not measured. The WeightControl software can, however, extrapolate the *theoretical* weight on a specified *control day* with a deviation of a few days. This makes it easy to compare calf growth performance.

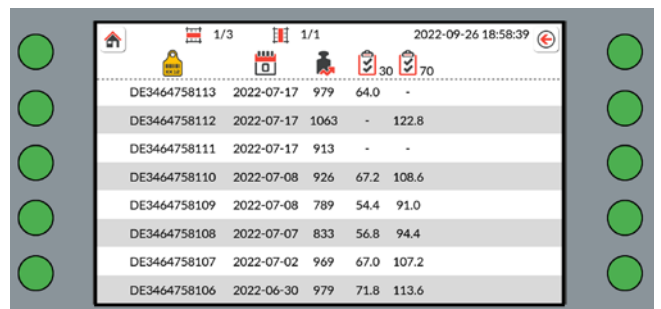

Transporter weights

You can weigh calves on the platform weighing scales with any transport trolley, such as the CalfBuggy (see p. 80). The weight of the trolley is stored in the software and is automatically deducted. It is possible to define up to 4 different "transporter weights". This can also be, for example, a strong trainee who always carries the calves himself and stands on the scales with them.





Management support

By recording calf weights, you create a database for important management decisions such as selection and feeding strategies.

Simple operation directly at the terminal

Electronic ear tags are recorded quickly using an ISO stick reader and automatically saved in the system. The 7" terminal screen displays the weight. WeightControl also shows the daily gain and the comparison to the herd average with every additional weighing operation. Further information about the calf (e.g. gender, calving process, colostrum quantity etc.) can be entered and saved using the WeightControl display.



Basis for important selection

When rearing comes to an end, this data can be automatically exported to other management systems, where it forms the basis for management decisions such as selections, feed strategies and the optimisation of work processes.

CalfGuide connection

All the data is not only saved in the WeightControl animal weighing scales but also transmitted automatically to the CalfGuide management application. You can view calf history information, such as daily weight gain or other information from connected MilkTaxis or calf feeders, both in CalfGuide and directly on the weighing scales terminal. This means complete integration of all calf rearing data in one system.

Weighing collections

Even if no electronic ear tags are available or you are reluctant to go through the hassle of manually entering the live ear tags, WeightControl provides a simple evaluation system: weighing collections. The aim here is to assign the calves to a certain "group" and to document their average weight development.

Each calf weighing operation can be assigned to a weighing collection. The weighing collections are numbered from 1-9999. You can then establish your own rules for the use of the weighing collection, for example:

1. Simple differentiation of female and male calves: male calves in collection 1, female calves in collection 2.
2. Are you a fattening farmer who takes calves from many different farms and would like to document the gains of the calves from the different sources? You can easily monitor increases by origin using one weighing collection for each supplier.
3. Do you have several calf pens, but have not documented in WeightControl or CalfGuide which calves are in which pen? Simply use one weighing collection per pen to determine the average weight of the group.

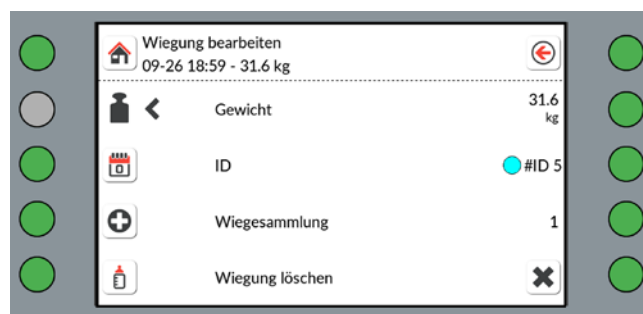

The weighing collection is always indicated in the data evaluation and export, i.e. you can evaluate the data quickly and easily by weighing collection even if no grouping is possible on the basis of the calf number.



Technical specifications

WeightControl "Base"

Scale plate (LxWxH)	120 x 98 x 10 cm
Operating terminal	30 x 44 x 120 cm
Max. load	2,000 kg
Weight	91 kg
Features	Data export as CSV file via USB or directly in CalfGuide, optional RFID stick reader, includes drive-on ramps

* Technical specifications subject to change

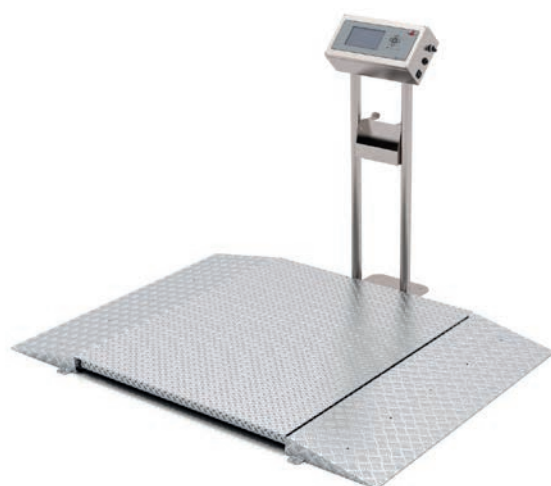

WeightControl "Single"

Overall dimensions (LxWxH)	210 x 94 x 132 cm
Interior dimensions (LxWxH)	161 x 48 x 100 cm
Max. load	150 kg
Weight	160 kg
Features	Data export as CSV file via USB or directly in CalfGuide, optional RFID stick reader

* Technical specifications subject to change



WeightControl "Multi"

Overall dimensions (LxWxH)	182 x 147 x 146 cm
Space in the box	2.5 m ²
Max. load	2,000 kg
Weight	340 kg
Features	Individual weighing function, 3 doors, front loader receptacle, data export as CSV file via USB or directly in CalfGuide, optional RFID stick reader

* Technical specifications subject to change



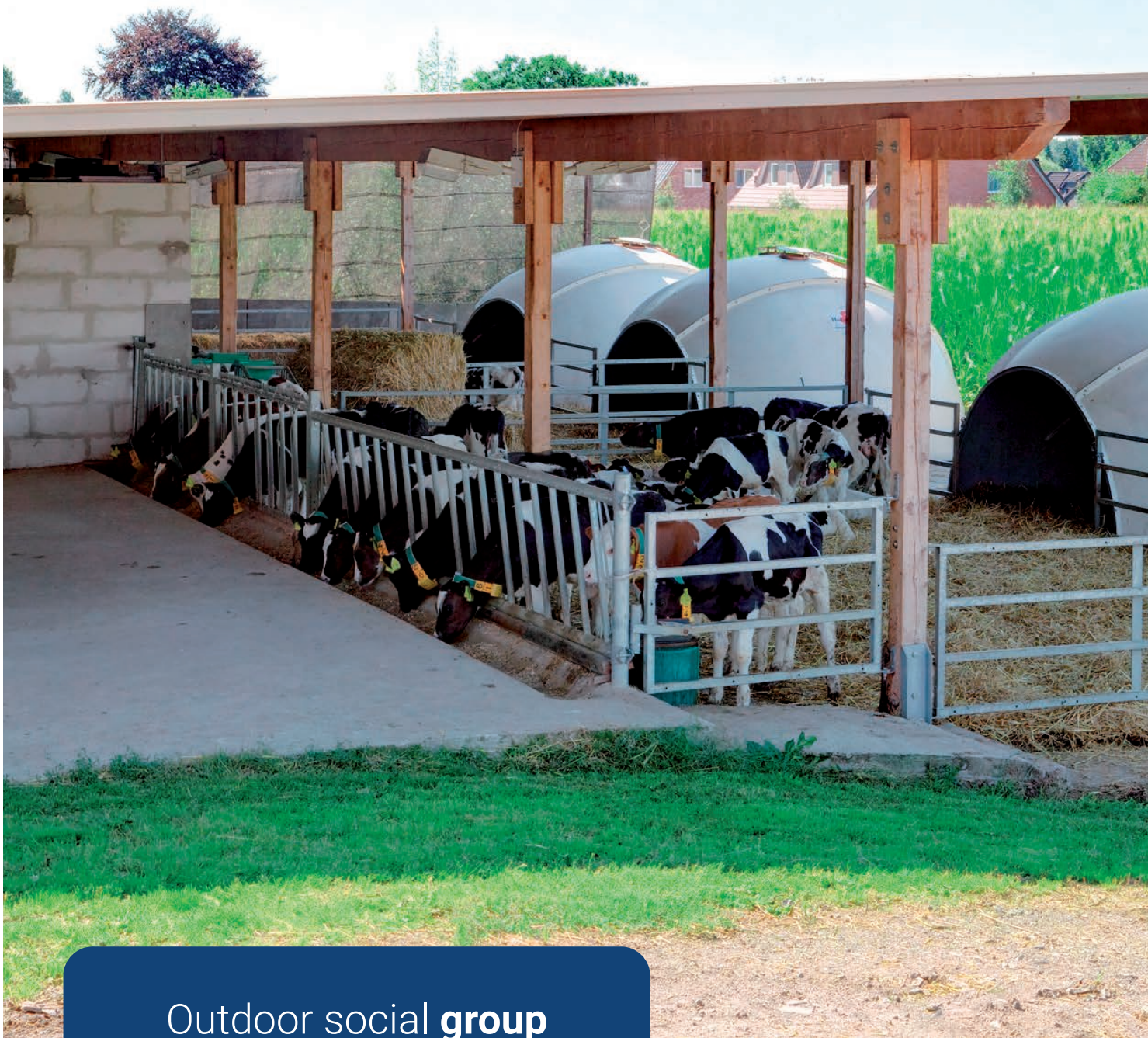

Outdoor social **group**
husbandry



Healthy outdoor housing

It is hard to imagine today: 20 years ago there was no other way to keep larger groups of calves professionally outdoors apart from expensive barns. It was the invention of the H&L Igloo that brought about the breakthrough of outdoor climate housing for calves in animal-friendly group housing. Today everyone knows that calves grow up healthiest in a group in the fresh air and achieve the optimum performance there.

An easy-to-transport igloo for up to 15 calves with optimum air circulation, favourable temperatures both in summer and winter made of almost indestructible GRP (glass fibre-reinforced plastic) is still the only option for many farmers today.



The roof not only protects the calves and the feed, but also creates a pleasant and protected place to work.



In the mobile Igloo Veranda, as a new building in the IglooSystem or also as an extension to existing calf barns. The Igloo is always an affordable alternative.



Healthy group housing in an outdoor climate. The calf decides where it feels most comfortable: in the sheltered igloo or in the covered run.



Healthy microclimate

An impressively simple design bridges the gap between a maximum exchange of air and a draught-free resting surface.

A place of retreat for your calves

Everyone knows that draughts in your calves' resting area stress them and make them sick. On the other hand, conventional calf barns need a high air flow rate to replace stale and contaminated air. Especially calves in the first weeks of life that cannot yet compensate for these negative influences through their own body heat production. You can offer up to 15 calves a draught-free yet well-ventilated shelter with the large-capacity H&L Igloo.

A unique ventilation system

The hemispherical shape of the Igloo ensures ideal ventilation: wind that hits the outside of the Igloo will result in negative pressure at the top of the dome (Bernoulli's Principle). Stale air is actively drawn out of the Igloo. Since the inlet opening is 12 times larger than the exhaust openings, the air velocity in the resting area remains extremely low. There are therefore no undesirable draughts in the calves' resting area.

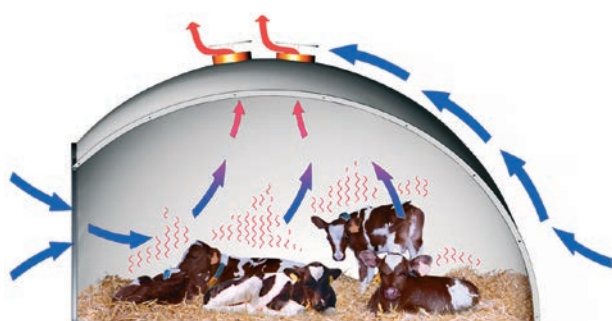

Never too warm – and never too cold

A special coating on the Igloo ensures maximum reflection of solar energy. For this reason, the Igloo does not heat up unnecessarily even on hot summer days and offers the calves a cool resting area. Even in winter, the temperature inside the Igloo hardly differs from the temperature outside. The animals do not start to sweat, which would lead to considerable problems.

Solve problems flexibly

Every farm has its own special requirements. It is therefore necessary to create barn construction solutions that are perfectly adapted to these conditions. The H&L Igloo will always integrate ideally into your farm.

Litter flap

The new opening on the middle part of the Igloo makes it much easier to spread straw: whether manually or by machine – you can simply bring in the straw from the outside and no longer need to be disturbed by frolicking calves.

Quickly set up

Two people need only 30 minutes to put up an Igloo. Precisely pre-drilled elements, the high-quality workmanship of the shells and easy-to-understand assembly instructions all help.

Mobile or fixed barn

Whether you prefer the mobile IglooVeranda (see next page) or a fixed calf pen along the lines of the IglooSystem, the concept of igloo housing offers ideal accommodation for your calves on your farm.

Solutions for existing buildings

Do you not have a suitable outdoor area for an IglooSystem? Would you prefer to use an existing building? Simply open the building to ensure maximum ventilation and the Igloo will provide the necessary microclimate inside. This permits you to use existing structures without expensive conversions and, alternatively, you can also use the room as a machine shed, for straw storage or the like.





H&L Igloo Technical Specifications*

Recommended number of calves	15
Resting area	Approx. 14 m ²
Length x Width x Height	3.9 m x 4.4 m x 2.2 m
Height of Entrance	1.40 m
Volumes	Approx. 20 m ³ /h
Weight	220 kg
Material	Hand-laminated glass fibre-reinforced plastic
Basic configuration	4 exhaust vents, transport hooks
Options	side curtains in the entrance for better weather protection in extreme conditions

* Technical specifications subject to change

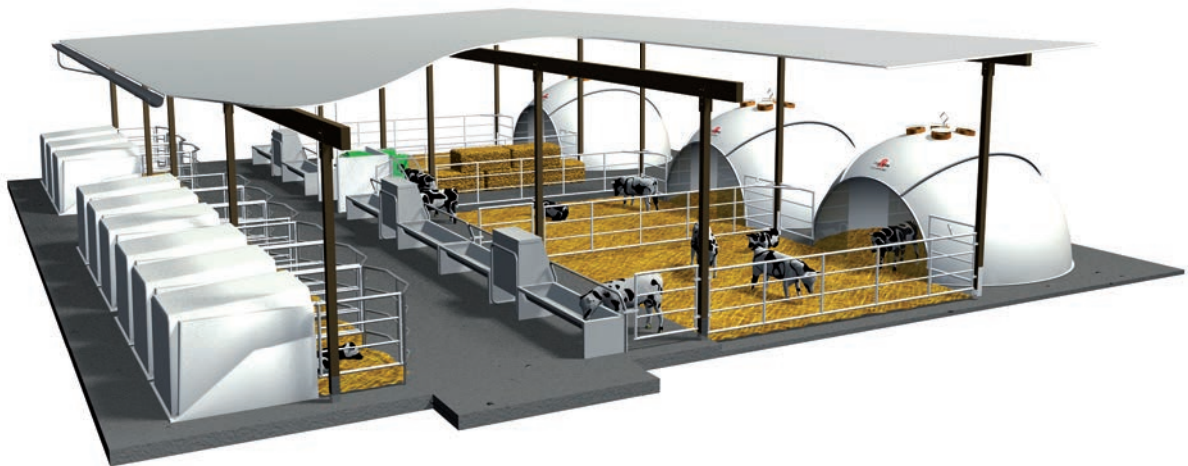



Weather protection for
outdoor group housing



Mobile igloo pens

Keeping calves outdoors is ideal and the H&L Igloo provides the perfect housing. However, the Igloo only comes into its own when combined with a covered run. Whether with a fixed roof or mobile as an IglooVeranda, calves benefit in both cases from the maximum amount of fresh air while enjoying protection from bad weather. It is not only the calves who appreciate the protected working area, but also humans. What's more, feed supplies and bedding stay dry. Mobility means flexibility, which in the case of the IglooVeranda is not only noticeable when mucking out, but also when developing the farm, when the calf barn can change location just like that. Discover the benefits of this innovative concept for yourself, which will also be easy on your pocket.



Wherever you wish to keep your calves, the Veranda is mobile and easy to move at any time.



Flexible calf housing: grows incrementally with your farm, keeping construction costs low.



The dual area principle: the calf can either lie protected in the Igloo or play in the run.



Focus on animal welfare

It is only when an animal is comfortable that it will deliver the desired performance. Nowhere is this principle more true than in rearing young calves.

Dual-area principle: the calf decides

Practice has shown that it is best to provide separate resting, activity and feeding areas. Calves at rest are then not disturbed by calves happily playing and jumping around. Calves can decide for themselves where they feel most comfortable in the IglooVeranda: in the igloo protected from draughts or running, lying or eating under cover in the fresh air.

Protection against the weather for humans and animals

The calves' outdoor area features a spacious canopy, and the H&L large-capacity Igloo offers up to 15 calves a draught-free yet well-ventilated retreat. And your working area is also protected from the rain, of course.



Plenty of space and movement

The H&L IglooVeranda consists of a resting area 5 x 5 m in size, which is the basic structure. Together with the area in the Igloo, this offers the calves 2.8 m² of space to lie down, eat or run around. This is almost twice as much as is legally required in the EU. The optional roof measuring 7 x 7.5 m ensures sufficient protection from precipitation and excessive sunlight. It can be extended to a width of 8 m on request.

Simple & economic

When the healthiest calves come from the most affordable calf barn, which is also easy to manage, then the choice is actually already made: for the H&L IglooVeranda.

Mucking out made easy

You can easily transport the Igloo and the Veranda with a front loader, with the calves staying locked in the Veranda and migrating with it to their new "home". Whether on the silo floor in summer or in front of the machinery shed in winter: you will always find a place for the H&L IglooVeranda. When you relocate the veranda every time you muck out, the calves always move to a new, clean location with low bacteria levels. UV rays, fresh air and rain provide disinfection.

Low investment costs

Conventional calf barns require an elaborate barn structure and ventilation systems. We recommend that you dispense with this and instead we offer the IglooVeranda with a play area and protected microclimate area. This solution is up to 70 % cheaper than conventional calf barns.

Variable feeding area layout

The 14 feeding places are equipped with a special locking safety fence. It is not possible for the calves to become caught unintentionally. Side elements and feed fences can be exchanged flexibly. Stainless steel tilting troughs are standard equipment in the feeding area. Optionally, nursing teat buckets and normal drinking buckets can also be used. This makes the IglooVeranda ideal for feeding with the MilkTaxi.



Cleaning of calf stalls for 56 calves in 1 hour and 46 minutes.

To the video (YouTube) QR code or <https://youtu.be/FZ3kzaXfjQM>



Options and features

Igloo Veranda basic configuration

- 2 H&L safety feed fences, with 5 or 7 places each
- 2 stainless steel tilting troughs
- 1 transport hook for the front loader
- Facility for a H&L feeder stall

IglooVeranda expansion options

- Roofing with drain hose dimensions 7 x 7.5 m or optionally 8 x 7.5 m
- Nursing teat bucket support
- Bucket holder (rings)
- Hay rack
- Concentrate dispenser
- Large bedding gate (2.44 m wide)

IglooVeranda technical specifications*

Recommended number of calves	14
Dimensions of basic structure	5 x 5 m Max. height 2.5 m
Roof area	7 x 7.5 m 8 x 7.5 m
Resting area	25 m ² under roof, 14 m ² in igloo (2.78 m ² per calf)

* Technical specifications subject to change

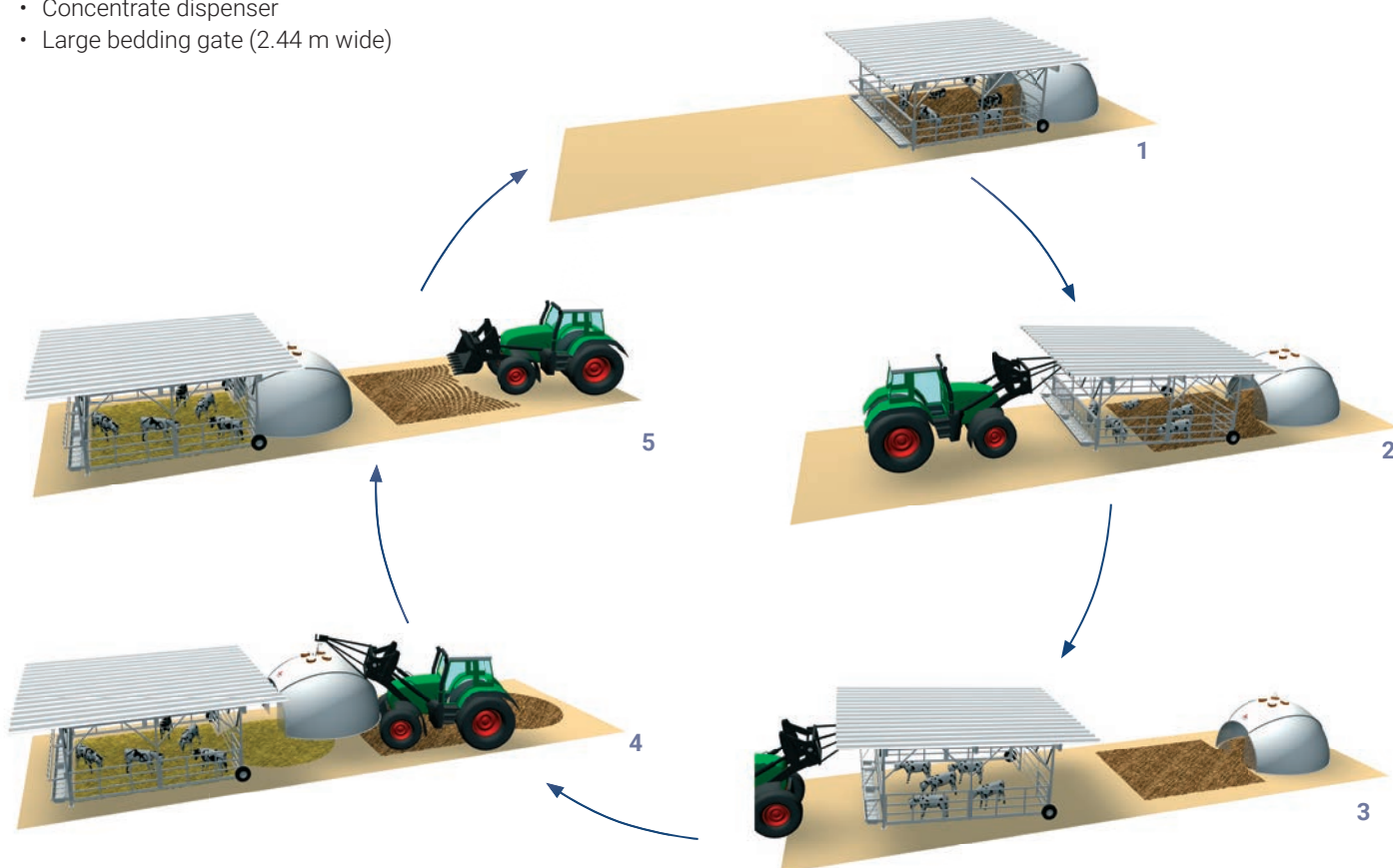

Moving and mucking out the IglooVeranda



Variable small group housing in **outdoor climate**



Effective small group housing

On small-scale and medium-scale dairy farms, there frequently are not enough calves to form large groups. And yet groups of five to seven animals present advantages in terms of workload and efficiency. This is because smaller groups allow the farmer to use the calves' age as a criterion of group inclusion more easily, thereby addressing the calves' individual needs more thoroughly.

Following the suggestion made by many of our customers, we have combined the advantages of small-group houses and the proven Veranda design. The result is the MultiMaxVeranda with similar advantages to the IglooVeranda, but adapted for small groups.



Protected workplace and easy mobile mucking out.



Can be extended flexibly from Uno to Duo or also in combination with single hutches. Proven Calf-Tel quality with a 10-year guarantee.



Small age differences in separate groups reduce disease transmission and promote healthy calf development.



Adaptable

It is only when an animal is comfortable that it will deliver the desired performance. Nowhere is this principle more true than in rearing young calves.

Various outfitting alternatives

The choice is yours: MultiMaxVeranda UNO, ideal for the smaller family farm with up to 5 places in the group and up to 4 places in individual pens. Or the MultiMaxVeranda DUO with two calf groups of up to 5 animals each, separated by a centre wall.

Separate, medium age groups

The smaller the age difference between calves of one group, the more consistently the animals will develop. Furthermore, smaller calf groups mean that the risk of infectious diseases spreading is reduced. The MultiMaxVeranda offers the perfect solution for many medium-sized farms with its groups of 5 calves.

Cost-effective

The veranda concept is the most cost-effective way of rearing calves. The MultiMaxVeranda makes all the financial benefits possible for small groups as well.

Maximum durability

The core of the MultiMaxVeranda is the Calf-Tel MultiMax, which has been designed with a unique feature: it's unbreakable! A special thermoforming manufacture process in combination with the highest-quality polyethylene results in unrivalled stability, durability, and longevity. The material is 100 % UV-proof. We provide a 10 year warranty on the plastic components of the MultiMax.

Mucking out made easy

You can easily transport MultiMax hutches and the Veranda with a front loader. The calves remain locked in the Veranda and migrate with it to their new "home". Thanks to the smooth surfaces of the MultiMax, cleaning it with a high-pressure cleaner and then sanitising it are as easy as ABC.

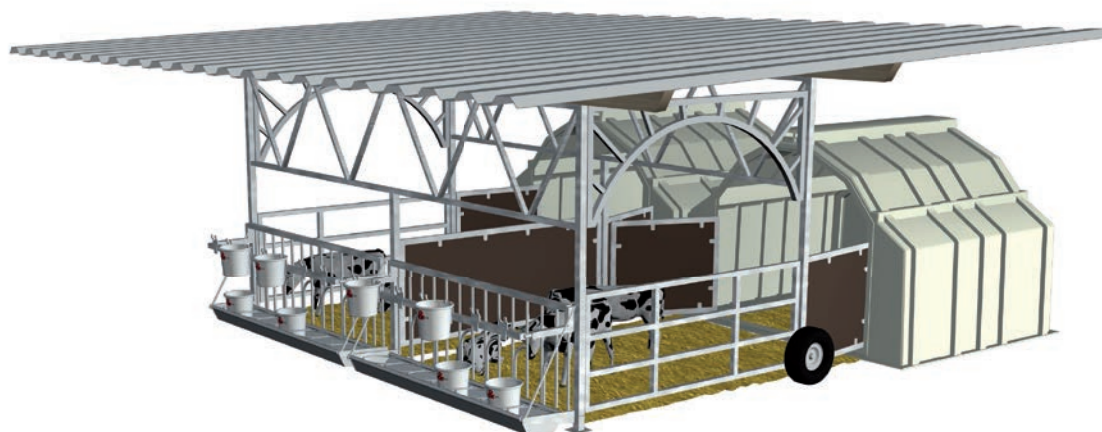

MultiMaxVeranda DUO



Options and features

MultiMaxVeranda basic configuration

- 1 or 2 H&L safety feed fences with 5 places each
- 1 or 2 stainless steel tipping troughs
- Closed separating fences
- 1 transport hook for the front loader

MultiMaxVeranda expansion options

- Roofing dimensions 6 m x 7.85 m
- Rain pipe
- Nursing teat bucket support
- Bucket holder (rings)
- Hay rack
- Concentrate dispenser

Technical specifications*

Outer dimensions of a single MultiMax	Depth: 2,20 m
	Width: 2,73 m
	Height: 1,83 m
	Weight: 107 kg

MultiMaxVeranda UNO / DUO* total area

Inside the MultiMax	5.3 m ²
Exercise area for each MultiMax	Approx. 7 m ²
Total surface area per calf	2.5 m ² (5 calves per group)
Veranda base frame	2.5 m x 5 m x 2.5 m
Roof area	6 m x 8 m

* Technical specifications subject to change

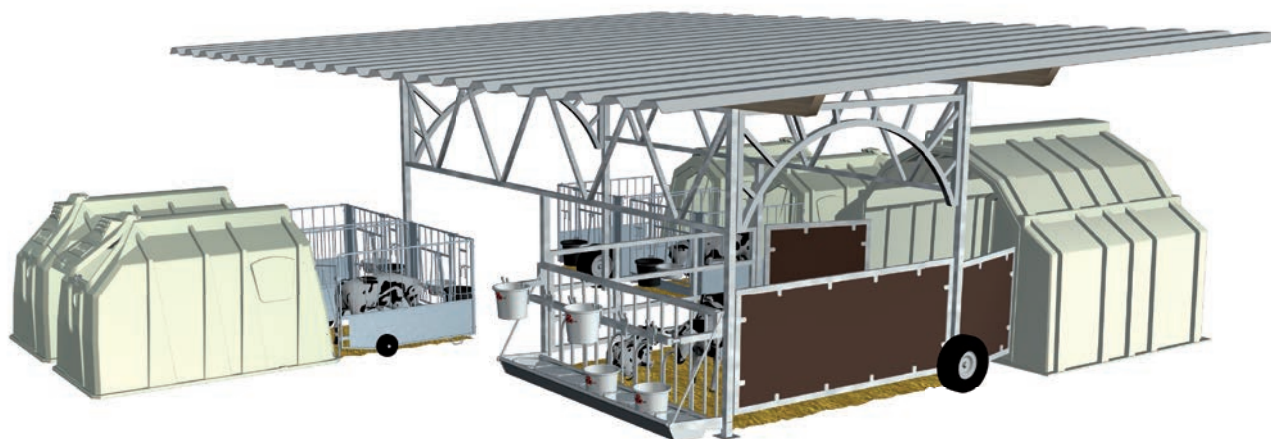

MultiMaxVeranda UNO



Modern pair husbandry, also following organic guidelines



The mini-group as a solution

We increasingly see farms housing two calves in a single hutch. What often began out of necessity in the event of twin births or a shortage of calf hutches is now standard accommodation for young calves on many farms. This is because disease transmission is kept to a minimum in this case.

And it is not only animal welfare activists who are casting a critical eye over the individual housing of herd animals. Organic farming associations today require its member farms to house calves in groups.

Holm & Laue has launched the TwinHutch and FlexyFence, the world's only housing solution for mini-groups for up to three calves in an area of 5.8 m².



Rearing calves is even more satisfying when they are happy.



Sufficient space for 2 – 3 calves, at the same time less space required than in individual housing.



Calves are herd animals and need social contact with other calves for healthy development. The first legal mini-group promotes this not only on organic farms.



In pairs rather than alone

So far, there has been no suitable calf hutch for housing two or three calves, because commonly used hutches contravene many animal welfare guidelines, as they do not offer enough space.

The first legal mini-group

Conventional hutches offer a maximum area of 3 – 4 m². A group pen for calves in Germany must provide at least 4.5 m² of space and offer each calf an area of at least 1.5 m². In combination with a modified FlexyFence, the TwinHutch offers a total area of 5.8 m². This is ample space for mini groups of two to three calves.

Feeding and drinking in pairs

The FlexyFence features two full-sized teat bucket holders, as well as an additional space for a third drinking bucket. Two additional bucket holders for concentrate and water complete the feeding area.

Compatible with organic guidelines

The group housing of calves is mandatory on organic farms. However, it is often difficult to form stable groups in periods with few calvings. With its generous space of 3.5 m² in the hutch and 2.3 m² in the run, the TwinHutch meets the guidelines of organic associations for housing two calves.

Economic arguments

Not only aspects of animal welfare speak in favour of the TwinHutch, but also advantages in terms of costs and performance.

Better performance

Studies show that calves from mini-groups exhibit better social behaviour, higher feed intake and increased growth even after weaning¹. This leads to an earlier first calving age and higher milk yields.

Less space required

In addition, the space and cost savings are arguments that appeal not just to organic farms. After all, with the same number of calves, the space requirement is halved and you need fewer igloos. Then you also have fewer igloos to clean.



Longer service life

The EU legal limit for individual stalls is a maximum of 8 weeks. Calves can be kept longer in a TwinHutch mini-group, as the limit for individual pens no longer applies. You can wean the calves off milk in peace and do not need to transfer them to the next group pen until they are 10 to 12 weeks old.

¹ Early pair housing increases solid feed intake and weight gains in dairy calves' J.H.C. Costa, R.K. Meagher, M.A.G. von Keyserlingk, D.M. 2015



Transport assistance

The transport assistance makes it much easier for you to transport the TwinHutch. The lever action makes it child's play to clean or move to a new location.



Dimensions TwinHutch*

TwinHutch exterior (Lx-WxH)	250 cm x 154 cm x 151 cm
TwinHutch interior (Lx-WxH)	243 cm x 146 cm x 136 cm
Dimensions with FlexyFence and buckets	432 cm x 156 cm x 105 cm
Space requirement	Approx. 5.8 m ²
Weight of the TwinHutch	43 kg

* Technical specifications subject to change

Click here to watch the video:



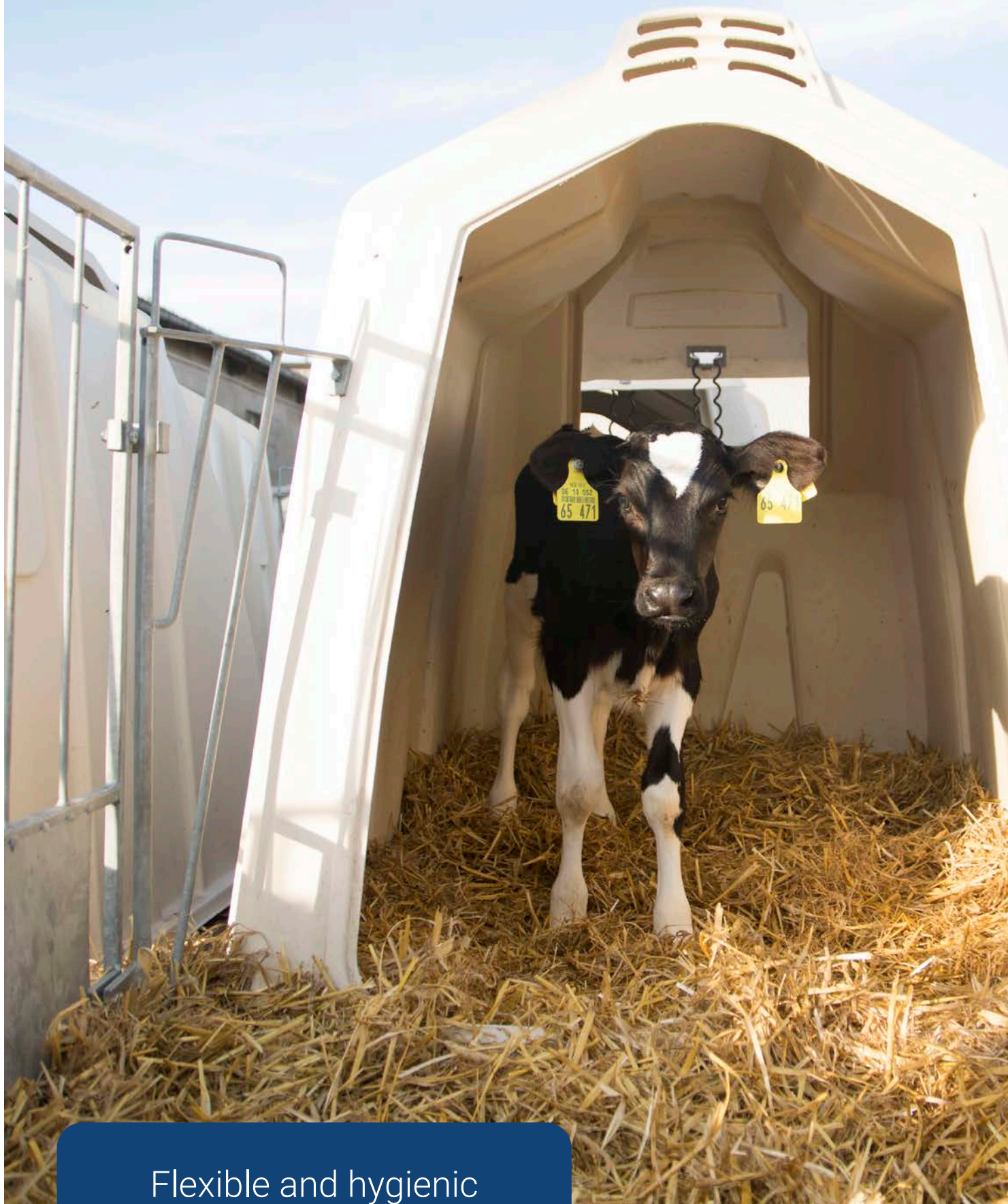

Flexible and hygienic
individual housing



The best hutch with the best run

Housing calves in individual hutches is becoming increasingly popular. Many farms perceive advantages in the spatial separation of the calves and the consequent reduction in germ transmission. Equally the trend towards intensive feeding of calves in their first three weeks of life (ad libitum feeding) results in calves being kept longer in individual hutches. Furthermore visual inspection of the animal is simplified in individual housing.

However, the choice of the "right" calf hutch strongly influences the profitability of your calf rearing, because individual housing is significantly more labour-intensive than, for example, group housing with automatic feeding. Then there are the local conditions on your farm, so individual solutions should always be tailored to your needs.

With the diversity of models and options of Calf-Tel hutches and FlexyFence on offer we provide the right solution for every farm. See for yourself.



The box can be entered while the calf continues to drink undisturbed. The foldaway hutch facilitates transport and cleaning.



Hutches in proven Calf-Tel quality with a 10-year guarantee combined with the innovative Holm & Laue FlexyFence.



The well thought-through individual housing: healthy calves thanks to a smart ventilation system.



A superior system with clever details

The two main criteria in individual housing: optimal housing conditions and effective management. Feeding in individual housing relies on many details. Think about what your calves would choose.

Indestructible

The Calf Tel hutches have a unique feature: they're unbreakable! A special thermoforming manufacture process in combination with the highest-quality polyethylene results in unrivalled stability, durability, and longevity. The material is 100 % UV-proof. We provide a 10 year warranty on the plastic components.

The smart FlexyFence

Our run features many convincing details that make daily work with calves a lot easier. The side-mounted wheels run alongside the straw mat and facilitate transport from the hutch to the washing area. The panels in the side walls protect the calf from draughts and prevent straw from blowing away. The hutch can be folded into the fence, but the fence can also be folded over the hutch.

Easy to clean and transport

All calf hutches, even the large ones, can be easily tipped into the FlexyFence using the handle on the rear and thus easily rolled to the washing area. This means that mucking out can be done quickly and easily with the wheel loader and the smooth surface of the igloo also makes cleaning the igloo a pleasant task.

Transport assistance

The transport assistance (photo see p. 59) easier for you to transport the hutches. The lever action makes it child's play to clean or move to a new location.

Click here to watch the video:

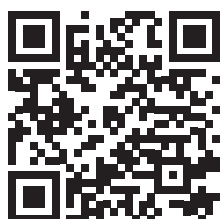

The perfect place for the feeder

The feed bucket is mounted next to the entrance door. You can leave the run through the door once the calf has been trained. The feed bucket hangs at an angle so that no residue remains in it.



Fresh water and concentrate

The FlexyFence is also equipped with two bucket rings to ensure that the calves always have fresh water and concentrate. We recommend feeding concentrates in shallow bowls.

Dry place for hay

It is always dry in the hutch and so this is the best place to provide hay in a hay rack. It is simply mounted underneath the litter flap and is thus easily able to be topped up quickly.

Optimum ventilation

The CalfTel hutches have a clever ventilation system with openings in the roof matched to the size of the igloo opening. In summer, the litter flap can serve as additional ventilation, guaranteeing fresh and optimum temperatures in the hutch at all times. In addition, the large opening provides an ideal opportunity to spread bedding in the hutch exactly where the calf most often lies.



The Pro II model

The big brother in the Calf-Tel family is ideal for single-stage housing in individual hutches up to 8 weeks of age. Because of the depth of the hutch, the calf is well protected at the rear, in particular in the winter or when the weather is humid. In this model, the multi-function flap not only ensures an ideal ventilation setting or easy bedding, but also makes it easier to check the animals from behind in the long box. The off-set entrance opening avoids draughts and offers excellent protection during poor meteorological conditions.

Pro II Dimensions*

Hutch exterior:	220 cm x 122 cm x 140 cm
Hutch interior:	212 cm x 114 cm x 122 cm
Dimensions with Flexy-Fence and buckets	380 cm x 126 cm x 98 cm
Space requirement	Approx. 4 m ²
Weight	Approx. 33 kg

* Technical specifications subject to change

The Pro II - OpenFront model

The OpenFront variant of the Pro II hutch facilitates access to the calf with the maximum open front, especially for taller people. In addition one has a good view of the calf and is able to monitor it in passing. The dimensions of the hutch are identical to those of the Pro II.

Pro II Dimensions*

Hutch exterior:	220 cm x 122 cm x 140 cm
Hutch interior:	212 cm x 114 cm x 122 cm
Dimensions with Flexy-Fence and buckets	380 cm x 126 cm x 98 cm
Space requirement	Approx. 4 m ²
Weight	Approx. 33 kg

* Technical specifications subject to change

The ECO model

The all-rounder in the Calf-Tel range of hutches. The Calf-Tel ECO is easy to handle and 40 cm shorter than the Pro II. Therefore, it is very easy to clean, store, and move. Its large entrance allows easy entry into the hutch and allows a good view of the interior and the calf. This model is suitable for housing calves up to 8 weeks of age.

ECO dimensions*

Hutch exterior:	187 cm x 118 cm x 137 cm
Hutch interior:	179 cm x 110 cm x 122 cm
Dimensions with Flexy-Fence and buckets	353 cm x 126 cm x 98 cm
Space requirement	Approx. 3.6 m ²
Weight	Approx. 21 kg

* Technical specifications subject to change

FlexyFence Duo

The adapted FlexyFence allows access to the neighbouring hut through a small gate. This gives you the flexibility of bringing calves together spontaneously or separating them, e.g. in case of infections or when feeding. A good concept to switch flexibly between single and mini-group housing.





Single pen canopy
for protected outdoor
climate housing



Protected individual housing

Raising calves in individual hutches in the first days and weeks of life has become accepted worldwide as an animal-friendly and hygienic form of housing. However, both humans and animals appreciate the additional weather protection provided by a roof. With conventional, permanently installed roof systems, the entire igloo system is no longer mobile, making easy cleaning and switching to different locations impossible. The Holm & Laue CalfGarden provides you with all the advantages of mobile individual igloo housing with the benefits of a similarly mobile canopy.

The perfect solution for the first weeks of your calves' lives: the H&L CalfGarden.



Provides a pleasant workplace with weather protection for the farmer – including easy mucking out and simple relocation.



Cost-effective canopy for single hutches. Easy mucking out and simple relocation included.



Healthy outdoor housing for calves, where bedding, feed and calves remain dry.



Shelter from a roof

What is critical for group rearing designs is no less critical for individual rearing: a roof for the hutches creates the optimum micro-climate, which is good for the calf. But what does this mean in practice?

Weather protection and dry bedding

Calves can spend more time outdoors in the open air, protected from the rain or hot sun by a large canopy. In addition, bedding stays dry longer, which delays the formation of ammonia. All this strengthens your calves' immune system and reduces respiratory diseases.

Dry feed

Concentrate, calf muesli or dry milk replacer are valuable feed-stuffs. They should always be provided fresh and dry. The canopy keeps all feed dry, thereby encouraging feed intake.

Sheltered work environment

The roof also provides the person working with the calves with a sheltered workplace and gives them more time with the calves. This increases the quality of work and allows signs of illness to be detected earlier.



Flexible housing

Who knows what the future may bring? Would you like a regular change of location or do you have increased calvings? The CalfGarden means you can always react flexibly.

Easy relocation

You can change location very easily with the CalfGarden every time you muck out. Both the canopy and the igloos are easy to move. Your calves will then always grow up on a clean surface that is not pre-contaminated with bacteria. UV light, fresh air and rain provide natural disinfection on the old surface until the next relocation.

Modular

The CalfGarden enables you to respond quickly and flexibly to changing requirements. We recommend the CalfGarden as an alternative to an expensive conventional calf barn with a fixed number of calf places. You save a lot of money and can simply add 10 calf places at a time in the future whenever necessary.





Options and features

CalfGarden basic configuration

- Base frame with 5 x 2.5 m distance between posts
- 2 push-on wheels with pneumatic tyres
- Front loader mounting

CalfGarden upgrade options

- Roof – the roof, with an area of 6 x 7.85 m, has a snow load of 85 kg / m². As the roof is optional, you can use local suppliers if you require heavier snow loads.
- Mobile or fixed – on request, the CalfGarden is also available as a fixed version that can be anchored to the ground.
- Storm protection kit – we recommend anchoring the CalfGarden in the ground with the storm protection kit to protect it from storms.
- Rain pipe – the rain pipe drains rainwater off to the side.

Calf Garden dimensions*

Basic frame	2.5 m x 5 m x 2.5 m
Roof area	6 m x 7.85 m

* Technical specifications subject to change

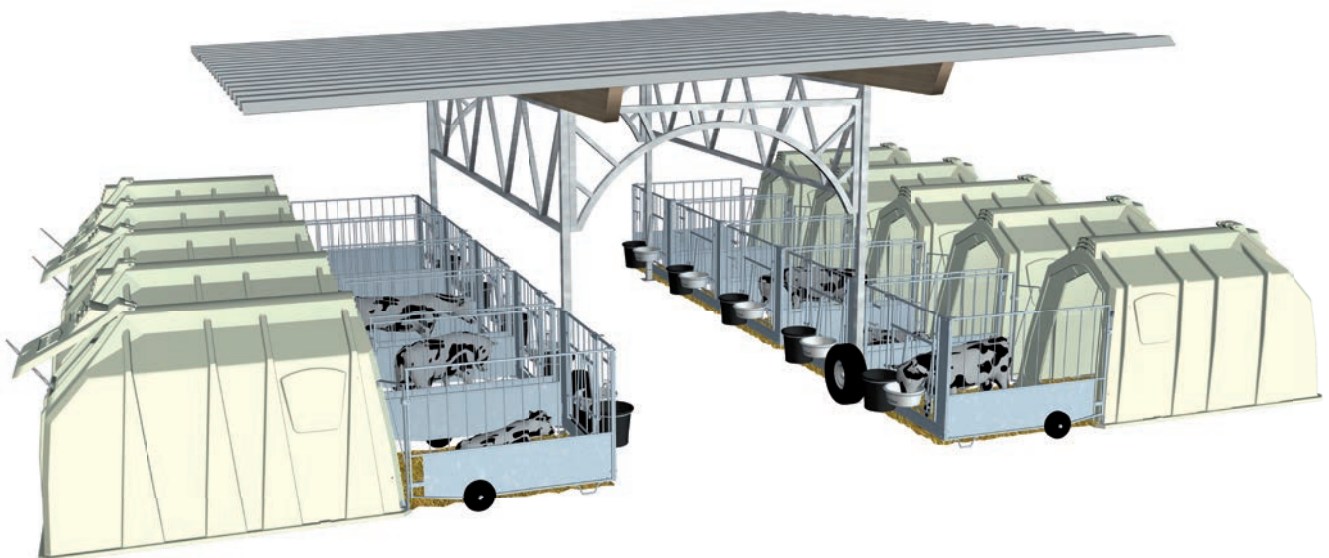



Flexible pen design thanks
to modular plug-in system



Housing in pens as an alternative to the igloo?

Even though outdoor climate housing is optimally suited to the demands of the calf, a sheltered barn also offers advantages for your calf rearing. Especially since modern ventilation and windbreak systems ensure an acceptable climate for calves.

The PenSystem from the USA has proven itself in practice in these cases. It is based on a simple plug-in system with individual pens. The pens can be arranged in different ways, depending on the layout of the barn and the work processes. The walls are free-standing on the floor and can be removed quickly and easily for cleaning.

The calves grow in the pens for as long as individual-calf housing is required. The pen elements can later be removed so that the calves are kept in manageable groups at the same location.



A good feeling of optimum calf rearing with little effort.



Using resources: individual pens can be assembled and dismantled absolutely flexibly inside a barn.



Hygiene in the calf pen: lightweight plastic wall elements are quick and easy to clean.



Flexible layout

The PenSystem is a modular concept that can be assembled in a wide variety of ways. More flexibility is not possible.

Different pen sizes

The side elements come in three different lengths, allowing you to create pens with areas of 1.6 m², 2.2 m² or 2.5 m² and thus adapt the pens exactly to your calves and the housing period in the PenSystem.

Easy Cleaning

The pen elements are very light and can be dismantled in one easy step and reassembled just as easily. This means they can be easily transported to the washing area. Cleaning is also very easy thanks to their completely smooth surfaces.



Less disease transmission

The closed side walls (with EU-regulation contact windows) reduce the exchange of germs between the animals and thus prevent the spread of diseases.

Closed or open rear wall

The rear wall can be fitted with the standard pen elements providing insulating protection for the calves that like to lie down in the area at the back. We recommend the open AirMax, which can be closed with a panel, for more fresh air in the box.

Variable front

The design of the PenFront is of central importance for effective feeding and quick access to the calf. Here, the PenSystem offers many well thought-out details.

PenFront with flexible door

The new PenSystem door can be opened in four different directions. You can choose whether the door should be hinged on the left or right and whether it should open inwards or outwards. This gives you maximum flexibility, even when things get a bit crowded in the calf pen. In addition, the PenFront features a large handle that is easy to open even in winter when you're wearing thick gloves.

Varied feeding

Calves are fed via two bucket holders for water and concentrate, and for milk feeding you have a choice between teat bottles and teat buckets. A particularly practical feature is that the bucket holding rings simply snap in and out. This saves space when transporting the PenFronts to the washing area.

The tried and tested FlexyFront

It is possible to choose the FlexyFront, which has been proven its worth in the individual hutches, instead of the PenFront. It gives a better view into the pen and the nursing bucket is positioned set off from the gate, which is a way of making it easier to train the calves. Another advantage of the FlexyFront is its open design, which significantly improves ventilation in the pen.





Form calf groups easily

Modular housing systems are also feasible with the PenSystem. Single or double pens can be formed with the permanently mounted posts. Mini-groups of 2 to 6 calves can then be created at a later stage by removing the middle wall. The front element is either the front of the proven FlexyFence (FlexyFront) or that of the TwinHutch for two calves. Particularly convenient: the PenSystem centre panel is very light and can be easily carried by one person alone.



PenSystem* dimensions

Length	183 cm (135 cm and 213 cm as options)
Width	122 cm
Height	114 cm

* Technical specifications subject to change

Variants

- FlexyFront or PenFront
- Side walls available in lengths of 135, 183 and 213 cm
- Wall brackets, for mounting against a wall when the rear panel is left out
- AirMax rear wall
- PenSystem post set for easily forming mini-groups



FEEDFENCE



Safe and practical
feeding place design



The right feeding place for any barn

Any calf barn, whether it is an outdoor climate barn such as the IglooVeranda, the solid structure of a conventional barn or even just a quick barn conversion, requires a well thought-out feeding system. This saves unnecessary walking and makes calf feeding faster and more reliable.

The options available to you are as varied as your personal desires and your calves' needs. Whether you feed your calves with the Calf-Expert calf feeder or with the MilkTaxi essentially determines which feed fence you use. What matters is making the right choice without restricting your future options too much.

With so much to choose from, you're spoiled for choice. Contact your Holm & Laue dealer. They know exactly what is important and you will avoid the mistakes that others have long regretted.



Easy handling and flexible feeding place layout for different requirements.



Cost-effective calf housing, as installation is also possible in old buildings.



Safety and calm for your calves thanks to quick securing in V-shaped feeding place openings.



Flexible adaptation to every situation

The needs of calves should also be taken into account when choosing the feed fence. You can house your calves in an animal-friendly way with the right equipment.

Safety for your calves

The H&L Feed Fence Headlocks are designed with V-shaped openings at every feeding place that allow the calves to insert their head and pull out safely. It is not possible for the calves to become caught unintentionally. A side grate on the bucket ring and the teat protection basket on the teat bucket holder prevent milk from being stolen. This means you can also feed larger groups of different ages individually without any problems.

Lock calves in quickly

Do you have a problem with reciprocal suckling? Then secure the calves in the fence for 30 minutes after feeding to prevent navel infections. The whole group of calves can be quickly secured thanks to a practical handle. Stragglers can also be secured individually.

Fast access

The H&L feed fence can be equipped with a rotating mechanism so that you can open it along the full front. This provides easy access to the pen for cleaning it completely. The manway with a lockable gate allows you to enter the pen and reach the calves quickly and safely.

Varied feeding place layout

The locking feed fence is designed for 6 - 12 feeding places. A novel telescoping design allows the fence to be placed between any two posts from 2.20 to 4.40 m apart. An ideal solution for old buildings. Just determine the distance you need; we will gladly advise on which telescoping feed fence is best for you. Each feed fence comes with a matching stainless steel trough. It is easy to access and feed remains can be tipped out effortlessly.

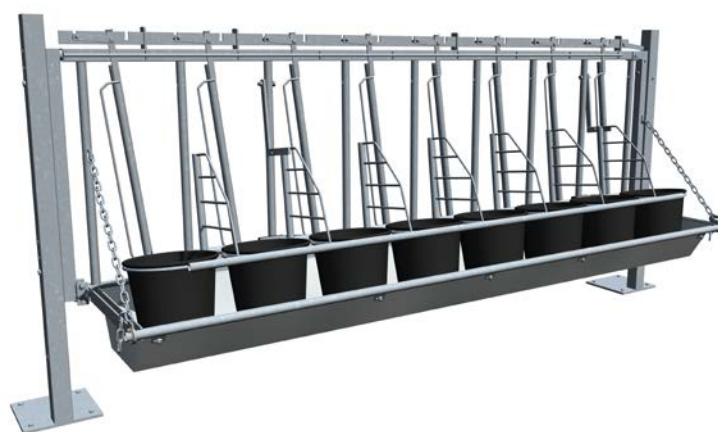

Feed fence with bucket ring holder, side barriers and trough

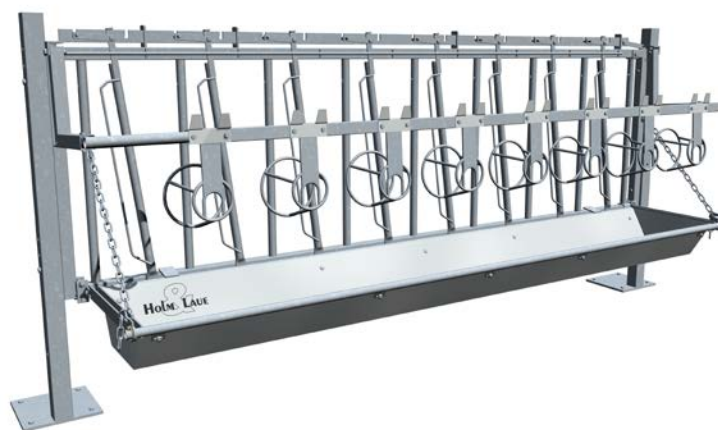

Feed fence with trough and teat bucket holder



Options and features

Feeding fence basic configuration

- V-shaped feed opening
- Neck size adjustment
- Central locking with handle
- Individual lock
- 6 cm square tube for easy assembly

Feeding fence upgrade options

- Varying lengths (see table)
- Teat bucket holder with teat protection basket
- Bucket ring holder with side barriers
- Manway
- Turntable with quick release
- Posts with and without base plate



Manway in the feed fence

Feed fence dimensions

Standard Feed Fence for Calves*

H&L feed fence (7)	Length 2.44 m, 7 feeding places, each 30 cm in width, not variable
--------------------	--

Telescoping Feed Fences for Calves*

H&L telescoping feed fence (6 – 8)	Length 2.20 - 3.15 m, 8 places at a variable length of 2.76 - 3.15 m; reduction to 2.20 m minimum possible for 6 or 7 feeding places by leaving out one or two places; feeding places each 33 cm in width
H&L telescoping feed fence (9 – 10)	Length 3.16 - 3.80 m, 10 places at a variable length of 3.40 - 3.80 m; reduction to 3.16 m minimum possible for 9 feeding places by leaving out one place; feeding places each 33 cm in width
H&L Telescoping Feed Fence Headlocks (11 - 12)	Length 3.81 - 4.40 m, 12 places at a variable length of 4.04 - 4.40 m; reduction to 3.81 m minimum possible for 11 feeding places by leaving out one place; feeding places each 33 cm in width

*Technical specifications subject to change



Concentrate dispenser

Concentrate feed should be given fresh and in small quantities at all times, so valuable feed does not get moist. This is difficult to achieve when distributed throughout the day. With an ad libitum dispenser only the exact quantity previously consumed by the calf is replenished. When feeding the calves concentrate, we recommend using our stainless steel concentrate dispenser with a capacity of approx. 50 l. This is easy to affix to concrete by using its base. Also optionally available as a wall mounting.

Concentrate dispenser technical specifications*

Width	1 m
Volumes	50 l

*Technical specifications subject to change



Roughage trough

A trough ensures that the calves cannot push the feed away. This ensures a high feed intake. The stainless steel trough is two metres in length. The supplied neck rail features an angled fixation that encourages a good body position during feeding, even with larger calves.

Forage trough technical specifications*

Width	2 m
Options	With galvanised neck latch

*Technical specifications subject to change

Hay rack

Calves like hay. It is important, however, that the hay is clean and can be accessed at any time. The large H&L hay rack is 1.5 m in width and can be safely placed on a pen separator. This is why refilling it is particularly easy, directly from the hay and straw reserve next to the pen.

Hay rack technical specifications*

Width	1.5 m
Options	Supplied with hooks that allow hanging it on a pen separator

*Technical specifications subject to change



Diagonal feed fence

Diagonal feed fences can be used in the calf pens as an alternative to troughs. This design is recommended, in particular, when calves are fed from a feed table. With a length of five metres, the H&L diagonal feed fence is equivalent to 17 calf feeding places. Bear in mind that the feed table should be raised by 15 cm. This is the optimum height difference for a calf feeding place.

Diagonal Feed Fence technical specifications*

Width	4.85 m
Options	17 feeding places Diameter of upper and lower pipes 2 inches

*Technical specifications subject to change



CALFHEALTH



Aids for a
healthy start in life



Small aids - significant effects

Calf-rearing also has many procedures which have to be carried out in addition to the everyday tasks such as feeding, providing bedding or monitoring the animals. Thus calves have to be frequently moved during the first weeks of their life. Or sick calves require special attention. For many of these areas there are practical aids which simplify day to day work.

In addition to the familiar products such as MilkTaxi, the H&L calf feeder and H&L IglooVeranda, Holm & Laue also offers several of these innovative aids in its range. They make the task of transporting the calves easier, provide support when calves are born weak or shelter the young animals from extreme weather conditions in winter for example.

At Holm&Laue the same standards apply for these small aids as for all other products: easy handling, longevity, innovative functions and maximum hygiene. We will be presenting a few of these products on the following pages.



Making your work easier with practical aids



Healthy calves mature into high-performing dairy cows



Promoting animal welfare and calf health with helpful products



CalfBuggy

CalfBuggy – simple and safer transport for calves

Transporting calves on the farm is a difficult task and tiring, particularly if one is on one's own. Pulling the calf across the yard on a halter and rope takes a long time and strains the nerves of all involved. Such situations can quickly turn dangerous too, if the strength required to lift the calf onto a wheelbarrow is not there or it is in danger of falling out.

The CalfBuggy lets you easily transport your calves over longer distances without putting safety at risk. It is easy to lower the buggy to the ground, allowing a calf to be simply loaded by just one person.

Simply unlock the twist lock to lower the cart to the ground. The calf can be ushered in comfortably through swing doors at the front and back and exit at the other end.

Once the calf has been loaded, simply press the grip downwards until the twist lock has engaged and the wheels are positioned for transportation.

The plastic grille on the floor of the CalfBuggy ensures that the calf stands safely and is quickly cleaned.

Thanks to the large-size wheels uneven and rough terrain as well as slush and snow are never a problem. They also provide ideal weight distribution to make pushing child's play.

A restraining device at the front of the CalfBuggy ensures that the animal can be held calmly and safely in place, for example for medical treatment.

What's more, the CalfBuggy is ideal for transporting other things too such as feed, straw or tools for example.

Technical specifications CalfBuggy*

Overall dimensions (LxWxH):	134 x 84 x 120 cm
Interior dimensions (LxWxH):	100 x 42 x 90 cm

*Technical specifications subject to change

CalfCoat calf jacket

In winter well protected – the H&L calf jacket

The H&L calf jacket provides ideal protection for your calves at low temperatures. It reduces the energy required to maintain body heat by up to 30 %.

An ideal addition for intensive energy rearing with metabolic programming.

If in spite of a healthy outdoor climate calves are sick in the Igloo, it is advisable to leave them in their familiar surroundings and provide additional protection with a calf jacket. Because moving to a poorly-ventilated warm barn causes additional exposure to bacteria and ammonia. The calf jacket is easy to adapt to different body sizes with adjustable leg straps and a practical fastening with Velcro at the chest.

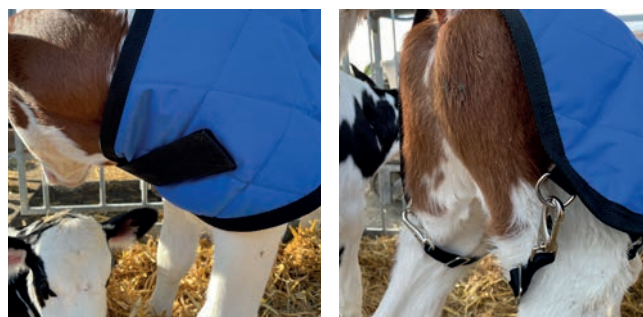

Excellent quality of workmanship

- breathable 3M Thinsulate material
- washable at 30 °C and disinfection with mild disinfectants
- durable metal fasteners on the leg belts
- low-wear edge reinforcement
- water-repellent outer material



CalfVital calf resuscitator

Lifesaving – the CalfVital calf resuscitator

It is essential to act quickly when calves are born weak. It often happens that the newborn calf is not breathing or the presence of fluid can be heard in the respiratory tract. The CalfVital calf resuscitator is a dual purpose pump which provides help quickly.



Draw off mucus

Amniotic fluid can be quickly removed from the respiratory tract with the pump's suction attachment (yellow). Two to three fast piston strokes are often quite sufficient.



Gently ventilate

If the calf subsequently fails to breathe, the CalfVital calf resuscitator helps to effectively ventilate the calf by means of a second attachment. An integrated valve prevents excessive pressure from building up. This protects the delicate pulmonary alveoli.

Cleaning and disinfecting are extremely simple since all components are made of plastic and furthermore can be quickly dismantled.

The storage bag is extremely practical and keeps the resuscitator clean and protects it. The CalfVital can therefore be kept directly accessible in the calving area.

Holm & Laue refractometer

Determine colostrum quality quickly and easily

Newborn calves have an insufficient level of antibodies and absorb these important protective proteins solely through their colostrum. This means that the young calves must be fed high-quality colostrum as soon as possible in order to develop a strong immune system.

The H&L refractometer determines the quality of the colostrum and in this way helps to ensure sufficient basic immunity. The digital refractometer measures the light refraction in the colostrum to calculate the so-called "Brix value" in %. This value correlates closely with the protein content of the milk and thus allows conclusions to be drawn about the quality of the milk.

The H&L refractometer is used in three important areas:

Testing colostrum

Good colostrum should have an IgG concentration of 50 mg/ml. This value corresponds to a Brix result of 22% and more. Samples returning a Brix value of less than 20% should not be fed to newborn calves. However, this milk still constitutes high-quality food for older calves.

Testing blood serum

Testing the protein content in the blood serum determines whether a calf has received a sufficient supply of antibodies. An immunoglobulin content of 10 mg/ml (7.8% Brix), measured after 24-48 hours, can be assumed to provide good basic immunity.

Determination of dry matter in whole milk

In addition to the actual Brix value, the H&L refractometer also determines the dry matter of the milk. This makes it possible to determine whether the milk contains enough ingredients or whether it needs to be enhanced with milk replacer powder.

SPECIALIST ARTICLE



Valuable information on all aspects of calf husbandry



Always up to date with Holm & Laue

Metabolic programming, daily gains, calf flu, diarrhoea, pair housing, heat stress, pasteurisation ... There are countless important issues in calf husbandry and rearing that need to be kept in mind and considered. After all, healthy, strong calves are the foundation for a farm that works well economically. As farmers, you save on veterinary costs and can enjoy calves that will develop into productive dairy cows. However, it is often difficult to keep up to date with trends and new developments in calf rearing. The following articles provide you with interesting background reports and practical tips for your everyday work in the calf barn.

Stay up to date at all times. Whether scientific studies, case studies, Webinars and announcements of dates: you will never again miss out on vital information with Holm & Laue's calf experts – and that over a variety of channels.

Read the latest professional articles, up-to-date practical reports and practical tips in the blog on our website.



Sign up for our Holm & Laue newsletter.

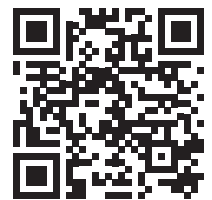

Visit us on Facebook and Instagram.



Check out our YouTube channel with over 60 videos.





Colostrum management and standard operating procedures (SOP)

Every farmer knows that it is vital to provide newborn calves with colostrum. But since a birth can never be planned, good initial care for calves is always a huge challenge.

Building up immunity is the number one priority

When a calf is born, one of the most important things is to ensure absolute hygiene and to avoid infections. However, there is much more to it than that: because in order to achieve good immunity, a calf must absorb more than 200 g of immunoglobulin IgG within the first hour of its life. Since it must be assumed that only about 40 % of first milk has an IgG content of more than 50 g IgG per litre, a calf must ingest more than 4 litres of milk, and only of high quality.

Studies show that calves fed this way are more resistant and later produce more milk. For example, Faber et al.¹ found that calves drinking 4 l of colostrum produced more milk later as cows (1st lactation + 950 kg, 2nd lactation + 1,650 kg). This trial on only 68 calves was corroborated by a field trial on 1,800 calvings by Soberon et al.² They found that calves that drank 4 litres of colostrum produced 1,027 kg more milk in two lactations than calves that were only given 2 litres.

However: not all mother cows have good colostrum and very few calves drink four litres in the first hour at the mother cow! Besides, you might think that calves are always born when you don't have the time to take care of them. So how can the new findings be translated into practice?

Standard operating procedures (SOPs)

This management method is nothing more than the clear definition of work steps that have to be completed when a particular task has to be accomplished. The primary care of calves is an excellent example of this.

For example, the coloQuick management system³: it is based on a supply of the best colostrum, which you freeze in disposable bags, subsequently thaw in a water bath as needed and feed directly from the bag to the calves.

The following two examples help to describe the work steps in SOPs:

SOP "Feeding colostrum to the newborn calf"

1. Birth: health check on calf and cow. The calf then stays with the mother for a maximum of 30 minutes so that she can lick it dry.
2. During that time, take frozen colostrum from the refrigerator or deep freezer and defrost it in the coloQuick for about 20 minutes.
3. Move the calf to an individual pen, disinfect the navel, administer iron under the skin or in the mouth.
4. Feed 4 litres of colostrum directly from the bag within the first hour of life.

SOP "Replenishing colostrum stocks"

1. Milk the colostrum cleanly (clean the udder thoroughly and milk it by hand).
2. Check the quality of the colostrum with a colostrometer spindle or refractometer.
3. Only put good quality in the bags and label bags with quality, cow number and date.
4. Freeze good colostrum and replenish the stock.



Make your own additions, laminate the SOPs and display them in the calving area and calf pen. Discuss the individual points in your team so that everyone understands the context. This will improve your employees' work performance and satisfaction because they know exactly what is expected of them. And of course the calves are given the best possible start in life and are ready for good growth and high, long-term performance.

1 Faber, S. N. et al., University of Arizona, The Professional Animal Scientist 21 (2005), 420-425

2 Fernando Soberon, Cornell University, June 2012

3 Further information at www.coloQuick.com



Higher milk yield through early metabolic programming

The calf enters this world still "immature". Many organs have not yet developed completely. Computer tomography studies have shown, for example, that the lungs take about 3 weeks to fully mature.¹ All other organs also exhibit significant development of cell tissue in the first few weeks. If the development of the calves is supported with higher amounts of energy and a better supply of nutrients than previously recommended, these organs will develop better and then form the basis for higher performance later on.

A cow needs a well developed udder for a high level of performance. In light of this, the following study is very interesting: Brown et al.² recognised that udder development can be positively influenced by more intensive feeding within the first 8 weeks of life.

Development of the soft tissue of the udder of calves according to BROWN et al. (2005)

Energy level 2nd to 8th week of life	Medium		High	
Soft tissue (g/100 kg body weight)	1.9		6.2	
Energy level 8th to 14th week of life	Low	High	Low	High
Soft tissue (g/100 kg body weight)	16	15	24	23

In this investigation it is clear that at a young age of just 8 weeks, development of the udder tissue is already taking place. Admittedly it is small, but it is nevertheless very much dependent on the energy supply of the calf. We are therefore able to positively influence udder development by feeding the calf early in the first weeks of life. However, the second line is more important: it is no longer possible to try to promote the udder system later on through greater energy if we miss the boat!

We know from other studies that providing older calves (from 6 months of age) with too much energy up to the time of oestrus results in massive fatty degeneration of the udder combined with reduced performance.

Studies on other animals (e.g. laboratory rats) even show another positive effect: exposing the organism to a high energy stimulus over a certain period of time in early life increases the release of insulin, which is necessary for the body to perform at a high level. It is interesting, however, that there is a sort of memory effect in the body's **metabolism**. This is because, when the high level of energy supply is adjusted (e.g. for a heifer to prevent a high level of adiposis), but then taken up again at a later point (e.g. intense feeding of the cow during first lactation), the body "remembers" its **programming** from earlier, and is in a position to perfectly support the metabolism processes of the body, through high insulin production.

This memory effect is known as "**metabolic imprinting**".

Soberon, Cornell University, 2012

In this respect, Soberon³ carried out extensive investigations into the topic of "metabolic imprinting" in cattle, and studied two farms with a total of 1,800 cows.

Here is a short excerpt from his results:

- The milk phase is the period of life, in which the udder tissue reacts positively to the increased supply of energy. This leads to more milk production later on.
- Calves fed ad libitum give birth to their first calf one month earlier.
- For each kilogram of increase daily intake during the milk phase, the animals achieved increased milk output of 850-1,113 kg in the first lactation.

There are numerous other studies that come to similar conclusions. This is reason enough for us to rethink traditional feeding programmes that have reduced calves' energy intake through milk in order to achieve an early intake of concentrate.

You can read about our practical recommendations on the following pages of this calf manual.

1 Dr Bernd Linke, 18273 Güstrow, Germany

2 Brown et al. (2005)

3 Fernando Soberon, Cornell University, June 2012; <http://www.ncbi.nlm.nih.gov/pubmed/22281343>



The digestive system of a calf

When feeding calves, it is important to bear in mind that the calves' enzyme system is geared towards digesting milk from the mother cow. The enzyme "chymosin", which is responsible for coagulating the casein in the milk, is prominent in this early phase. 80 % of the enzymes secreted fall on this rennet ferment. This means that only whole milk or milk replacer with a high proportion of skimmed milk powder should be fed in the early phase. Whey protein is digested primarily by the enzyme "pepsin", only 20 % of which is secreted in the abomasum during the early phase. This is why plant-based proteins cannot yet be used. CMR from whey powder can therefore lead to reduced performance (growth) in the early phase or, if plant-based proteins are mixed in, even to diarrhoea problems¹

The phase of sole milk digestion lasts approx. 4 weeks. Only then can calves gradually digest plant-based proteins because the enzyme spectrum changes. This means that we have to respect two different feeding phases in the early rearing of calves with milk feeding:

- a) Start-up phase: the first four weeks with exclusive energy supply from milk. Highly digestible whole milk or CMR with at least 30 % skimmed milk should be used.
- b) Feeding phase: the period from about the fifth week of life until weaning, when the digestive system has to adapt quickly to plant-based nutrients. This is when you should prepare the calves for the increased intake of dry feed.

How much energy does the calf need to consume?

According to DLG nutrition tables, a calf with a body weight of 50 kg and daily growth of 400 g requires approx. 15 - 16 MJ ME / day. This corresponds to approx. 6 litres of whole milk of 1000 g of CMR/day.

However, if you factor in the metabolic effects mentioned above, 400 g of daily gain is not sufficient. The American DCHA (Dairy Calf and Heifer Association) sets out in its Golden Standards that a doubling of the body weight up to the weaning period should be aimed at with a period of 8 weeks and therefore a daily growth of 1,000 g. Growth rates of 1,000 g per day require an energy intake of over 20 MJ ME/day, however. This means more than 8 litres of whole milk or at least 1,250 g of CMR/day.

These values even need to be increased at temperatures below 10 °C, as calves' sustenance requirements increase in winter. When temperatures are significantly below freezing, it is difficult to raise energy intake enough to continue to achieve 1,000 g daily gains. Calf jackets have proven to be very helpful in this case because they reduce the maintenance requirement by as much as 30%, leaving more energy from the milk for growth. Research in the U.K. found that calves wearing calf jackets showed 5.3 kg more growth and GBP 2.90 lower feed costs during the winter.² Further measures such as sufficient dry bedding, tasty concentrated feed and draught-free housing promote good growth even in cold temperatures.

¹ Dr Hans-Jürgen Kunz, Schleswig-Holstein Chamber of Agriculture, 2016, Professional article: "How does digestion work?" http://www.lksh.de/fileadmin/dokumente/Bauernblatt/PDF_Toepper_2016/BB_36_10.09/52-53_Kunz.pdf

² Gill Dickson; Simon Marsh, Harpers University, 2014, „Faster growth and lower feed costs from Calf Coats“



Discussion: "Ad libitum feeding"

A proven method of supporting calves' metabolic programming is to feed them acidified whole milk using the ad libitum method. This means that the calves always have a full bucket of milk available and drink as much as they like. An intake of more than 15 litres per day can be observed after 2-3 weeks.

This feeding method leads to very rapid growth of sometimes more than 1,000 g per day. If done correctly, the calves become very robust and resistant. The following tips should be followed for successful implementation:

- Only highly digestible milk, such as whole milk or CMR with at least 50 % skimmed milk powder, is suitable for ad libitum feeding.
- The milk needs to be acidified to pH 5.5 so that it stays fresh in the bucket for longer (including in summer). Greater acidification is not recommended, as its palatability suffers too much and high intake levels are not achieved.
- Acidification should be performed with acid complexes that work at different temperatures and with different milk compositions. Formic acid, which was popular in the past, is not always the best choice.
- The storage quality of acidified milk can also suffer in summer temperatures above 25 °C. The milk should therefore be pasteurised beforehand, because no significant germ development can be seen in pasteurised milk, even at temperatures of 30 °C for 12 hours.
- The milk is infused at a maximum of 20 °C and remains at room temperature. Excessive heating can lead to the milk flocculating during acidification.
- Milk buckets should be fitted with a tight-fitting lid to keep out flies and dust.
- Care must be taken to ensure that the buckets are constantly filled so that the calves do not drink too hastily or too much. This means that calves do not go hungry before the next meal and only consume a small amount.

- Ad libitum feeding must be started immediately after birth. Once calves have been fed restrictively, they should not be switched to ad libitum abruptly, as they tend to overfeed.
- The ad libitum phase should not last longer than 3 weeks. It is important, however, to prepare gently for feeding afterwards. The metabolic feed curve on the CalfExpert¹ has proven its worth for this purpose.

Prejudices against ad libitum feeding

Too much milk leads to diarrhoea: In the procedure described above, the calves call up their milk in several visits. So even though they have a full bucket available, only small amounts are ever ingested.

Too much milk prevents the early intake of concentrated feed: The opposite is the case. Practice and many scientific studies show that calves that take in a lot of milk demonstrate a higher intake of concentrated feed. This seems to be related to the metabolism's increased demand for high energy turnover.

Buckets freeze over in winter: In fact, there is a risk of freezing in frosty conditions. It can then be difficult to get the frozen milk out of the bucket and teat. However, calves readily consume lukewarm milk in winter and also achieve a higher energy intake and correspondingly better growth than with rationed feeding.

A lot of milk is thrown away before every meal: True, a large amount of milk may be rejected, especially in young calves. However, these costs are more than compensated for by improved growth rates and an earlier age at first calving.

¹ See article 'Latest recommendations for calf feeding at automatic feeders' in this manual



New recommendations for calf feeding at the calf feeder

In order to metabolically successfully implement scientific conclusions in practice, and thereby rear healthier calves with a better performance prognosis, the historical nutritional recommendations need to be revised.

Traditional feeding programmes have a hidden risk.

Traditionally, feeding programmes based on the principle of 3 litres per meal time, each with 120-130 g of CMR are recommended. In this case, the calves are provided with approx. 750 g of CMR/day. A thoroughly popular opinion until 2010. These programmes were also used with calf feeders.

In addition to the low energy concentration, however, there is a second risk with calf feeders: hunger when milk is not called up.

Since the total volume for the calves is distributed across 4-6 visits per day, each calf receives just 120 – 150 g of CMR/day. When training calves, there are always some animals that need a few days to get used to the feeding method. They often miss a meal or two in the process. Should a calf miss its second visit and on the second day only come to one or two meal times, this means that it often receives only half of the CMR instead of the desired 750 g per day. Such calves then do not even receive sufficient energy for their own sustenance needs, and are then very susceptible to diseases.

The supposed advantage of the many small portions at the automatic feeder may therefore also be a risk factor.

Calf feeding redefined

All of this means that we must rethink calf feeding.

1. Feeding parameters must be adjusted based on precise and individually balanced feeding curves to suit the individual needs of the calves.
2. Calf feeding up to the milk weaning phase is split into two phases:
 - a. **Initial phase:** intensive feeding when the organs mature (first 28 days of life).
 - b. **Feeding phase:** to support the development of the calf into a ruminant.

3. The so-called metabolic factor can be defined as a measure of the calves' energy supply in the initial phase. Metabolic factor can be defined. It states how much CMR or dry matter of whole milk the calf has consumed up to the 28th day. The higher this figure, the higher the subsequent performance potential of the calf.

Implementing the findings in the programming of computer-controlled calf feeders

First of all, every farmer should determine how intensively they wish to rear their calves. Intensive ad libitum feeding (* See discussion: "Ad libitum feeding") over 2-3 weeks is not the right way for everyone.

A distinction must therefore be made between two feeding strategies:

"Economy feed curve"

The standard curve of a feeder should ensure a daily intake of approx. 1,000 g of CMR in the first 4 weeks. This corresponds to the recommendations for moderate rearing with average growth of approx. 400 - 500 g / day.

This is achieved by starting with a quantity of 6 - 7 l per day. With this quantity, we recommend increasing the CMR concentration to 145 g / l in the initial phase and then reducing this to 135 g before the actual feeding phase. The calves are weaned in very small steps after 35 days, so that they are completely weaned at 70 days. This feed curve requires a total of approx. 50 kg of CMR per calf. It is important, however, that more than 50 per cent of the energy (27 kg of CMR = metabolic factor) is administered already within the 28-day initial phase.

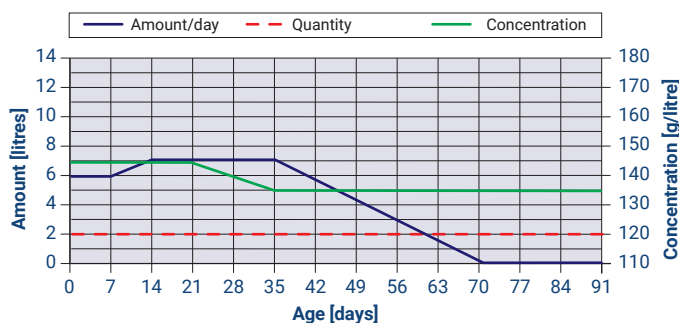



It is important that the visit amount is set at 2 l from the very beginning. The calves that do not call up the second feed per half day still receive an amount of energy of approx. 600 g per day. This amount at least covers the calf's subsistence requirements and avoids the hunger of the calves being weaned, as described above.

The metabolic feed curve for greater performance

As an alternative to the economy curve, we recommend a metabolic feed curve for farmers who wish to achieve significant increases in performance.

This feed curve dispenses with a feeding phase and feeds 8 - 10 l of milk per day in the initial phase. In the process, the farmer accepts that the calves may not call up the complete quantities from the outset. The concentration starts at 175 g of CMR / l. The intake of CMR in the first initial phase is 1,400 g and more. This enables the calves to achieve daily gains of over 1,000 g. This high level of supply causes the calves to metabolise additional amounts of CMR in a ratio of 1 kg of CMR kg body mass.

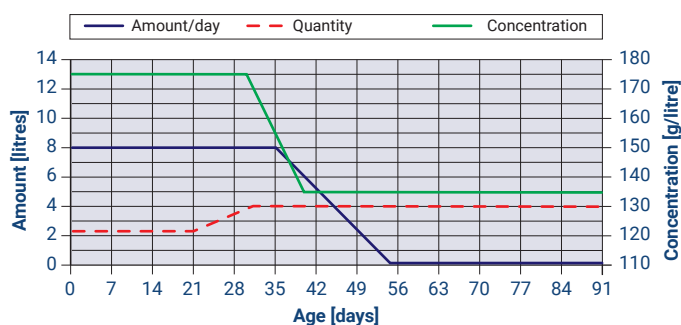

The metabolic factor in the 28-day initial phase amounts to approx. 38 kg of CMR. This amount of milk powder was often not reached in the previously recommended feed curves until the end of rearing at 10 weeks.

As with the economy curve, the metabolic feed curve relies on feeding the calves by reducing the concentration of CMR at an early stage. This ensures that the calves are prepared in good time for the intake of concentrated feed. This procedure ushers in the **feeding phase**. We reduce the available energy.

This encourages the calves to compensate for their emerging hunger pangs with dry feed. Furthermore, the calves still receive a lot of milk for a certain time, which can suppress the inclination to suckle each other.

The metabolic feed curve is ideally suited to the weaning of calves that were previously fed ad libitum in individual pens or hutches.¹ A change of stall should take place in this case no later than the third week of life.

With the metabolic feed curve, you can consider reducing the milk phase by 2 weeks to 8 weeks. The theoretical consumption of CMR for a weaning period of up to 8 weeks is about 56 kg, for a 10-week feeding period it can be over 70 kg, depending on the amount of milk actually consumed.

Prerequisites for intensive feeding programmes

Three things are important for such programmes to succeed:

1. High-quality and highly digestible milk replacers or whole milk must be used. Low quality may cause diarrhoea caused by feeding.
2. The feeding method must be able to feed each calf individually, because the adjustments in quantity and concentration can only be made if each portion is freshly prepared for the calf in question.
3. The farm manager and staff need to have a good eye for the calves. Despite improved health, diarrhoea may occasionally occur, which is difficult to distinguish from thin faeces that occur when the calves consume a lot of milk. Here, it can be useful to have a management system that precisely analyses the calves' visits and feeding behaviour and clearly shows the calves that are conspicuous to the farm manager on a PC or tablet (e.g. CalfGuide).

¹ See discussion on 'Ad libitum feeding' in this manual



Integrated scales in automatic calf feeders

The most comprehensive weight information is obtained from animal weighing scales that are integrated directly into the drinking station of calf feeders. The weight of the calves is recorded on each visit and extensive data are generated that provide information on the calves' development on a daily basis.

Since calves suffering from diarrhoea lose weight immediately, although they are actually still drinking quite well, they can be identified more quickly based on the alarm list by weight rather than on the list of milk consumption. Severe diarrhoea can often be avoided by early treatment, reducing the need for medication.

The second important reason for equipping a feeder with weighing scales is the possibility of weaning the calves from the milk according to their individual weight development. This method weans calves that consume concentrate and roughage early from milk more quickly. This saves costs for milk replacer or whole milk and promotes the calves' further development into ruminants.

And in addition, the animal weighing scales, when combined with management programs and analysis software, provide very detailed information on the calves in the evaluation about how calves are likely to perform in the future. Various studies on the subject of "metabolic programming" show that calves with high feed intake and above-average growth also have a higher milk yield later in lactation. For example, Soberon et.al found that for 100 g of increased daily gain as a calf, 85-111 kg more milk was produced later in lactation.³ So if calves grow at 1000 g a day instead of 600 g, up to 450 kg more milk can be expected in the first lactation.

Thus, in addition to the genetic value of the calf, the information on animal weight provides another important piece of information when it comes to the question as to which heifers should stay on the farm and be reared and which animals should be sold. These additional selection parameters are becoming increasingly important, particularly in times when resource conservation and environmental regulations often call into question whether all animals should be reared.

It is also important to know when the calves have matured. The diagram below shows the feed and weight curves of two calves. Both calves were inconspicuous when consuming their feed and almost always called up their full amount. However, it is clear to see that the calf at the top only weighs about 75 kg at the end of the rearing period, while the calf at the bottom finishes the milk phase weighing about 90 kg. The first calf did not gain any weight in the phase up to 20 days, while the second calf grew continuously at about 900 g / day. The first 3 - 4 weeks of a calf's life are crucial for metabolic programming and early udder development. The second calf is therefore clearly to be preferred to the first calf in the selection process for the future dairy herd.

These points show that Peter Drucker's quote is more relevant

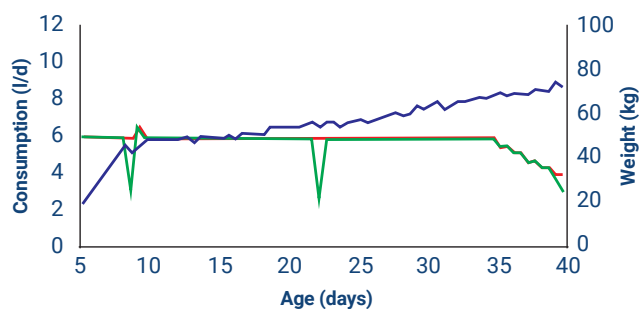

The feeding and weight histories of calf number one

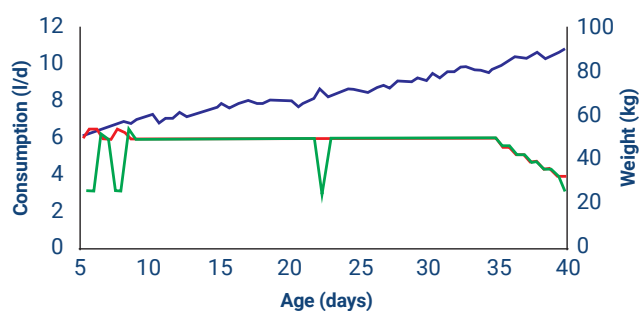

The feeding and weight histories of calf number two

than ever. Basing management decisions on gut instinct is rarely a good thing. Picking options based on little information is no better. In calf rearing in particular, a lot of information has to be collected in order to set the farm on the right course. "Calves are the future of the farm" says every second publication on the subject. Let's finally start acting accordingly!

3 Fernando Soberon, Cornell University, June 2012; <http://www.ncbi.nlm.nih.gov/pubmed/22281343>



Pasteurising whole milk

Whole milk is a valuable feed source for calves¹ Unfortunately, this milk is often contaminated with bacteria. Pathogens that cause mastitis in cows (*E. coli*, staphylococci, streptococci) also play an important role in problems in the calf barn. These pathogens enter the calf's digestive tract directly through the milk and may cause diarrhoea. Practical experience suggests that heifers that were fed contaminated milk in the past are susceptible to mastitis diseases later in life.

Pasteurisation means treating the milk with heat to kill off germs. Pasteurising calves' milk has been a standard procedure in the USA for decades. The flash pasteurisers commonly used there heat the milk to 73 °C for 15 seconds² However, the technology is very costly and is generally only worthwhile for farms that have to pasteurise upwards of 500 litres of milk.

Batch pasteurisation at 63 °C for 35 minutes has proven to be practical for other dairy farms. After this time, 99.5% of the important disease pathogens are destroyed, while the critical nutrients in the milk are preserved. This process is also used in the MilkTaxi pasteuriser.

It is essential to store the milk in a cool place to maintain its quality until it is pasteurised, especially if it is not to be consumed for another 12 hours. The MilkTaxi pasteuriser is equipped with a simple and cost-effective water cooling system. Temperatures of 10 – 20 °C are generally sufficient to keep the milk stable for half a day.

How does milk pasteurisation fit into the daily workflow?

Pasteurisation usually takes 2 – 3 hours, often too long to feed the calves directly after milking. This is where automatic, time-controlled pasteurisation in the early morning hours comes in useful. Pasteurised and precisely temperature-controlled milk is then ready to be fed in the MilkTaxi in the morning. Therefore we recommend the following procedure (e.g. evening milking):

- 7:00 pm** Pour the milk into the MilkTaxi and cool down to water temperature. The start time is programmed in the timer, e.g. 4:00 am.
- 4:00 am** The MilkTaxi automatically starts heating the milk.
- 6:00 am** Pasteurisation is complete and the milk is available at drinking temperature.
- 7:00 am** After cleaning the MilkTaxi, the morning milking is poured in and cooled before the milk is pasteurised for feeding in the afternoon.

What milk should be pasteurised?

Whole milk should generally be pasteurised for safety reasons. Even if there are no problems with disease, this reduces the potential risk if a pathogen does manage to infiltrate the herd. However, it is particularly important to pasteurise non-marketable milk (mastitis milk etc.) before feeding it, as it carries the risk of transmitting diseases from cows to calves.

It is recommended to pasteurise milk, especially for ad libitum feeding, as this improves the shelf life of the acidified milk in the feed buckets.

We do not recommend at all pasteurising colostrum and milk that has undergone previous heat treatment. Milk containing antibiotics should never be fed to calves because of the risk of developing germ resistance. Pasteurisation does not inactivate the antibiotic effect.

Process Steps in an Automatic Pasteurisation Cycle

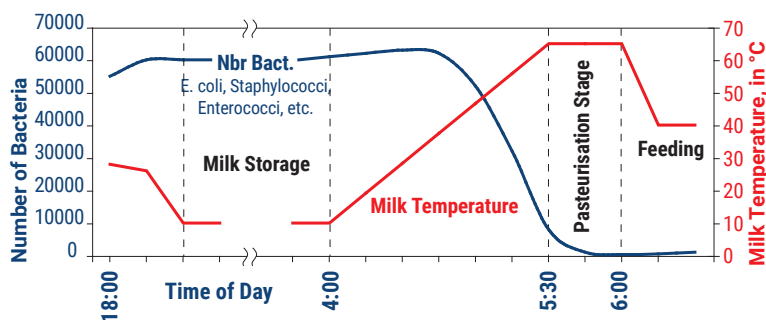

¹ See also see p. 86.

² Further information can be found at www.calfstar.com



How do I set up my barn for a calf feeder?

When choosing a feeder, make sure that it can be used flexibly and that it can be retrofitted with all options later on. With such a product, you can be certain that you will not have to settle for second best when you install and operate the system.

There are a few other things you should be aware of:

- Ensure a reliable and appropriate mains power supply.
- Use water of good drinking quality and use a water filter.
- Ensure cleanliness around the feeding station. This is the area most visited by the calves; it may get dirty very quickly.

Therefore:

- Position the HygieneStation approx. 15 cm above the ground on a stand.

Create a liquid drain under the station. This can lead into the drainage channel you need for the HygieneStation.

- Position the station outside the normal bay area.
- Clean this area regularly. The tilting function of the HygieneStation is particularly helpful in this case.



- Place a water hose with a sprinkler next to the machine for easy and quick cleaning of the surfaces.
- When planning, make sure there is enough space around the feeder and the HygieneStations. This will make subsequent tasks such as refilling the CMR, replacing the teats and suction hoses or the annual maintenance very easy. Space for two pallets should be provided for the milk replacer powder. When using whole milk, provide sufficient space for a suitable milk cooling tank (e.g. MilkJug from CalfStar).
- As far as possible, use buried conduits to route wiring as well as the tubing to the teats. To avoid rodent intrusion, make sure that the butts of the conduits are sealed.

- You should install a water connection for teat cleaning directly at each hygiene station. This line can be integrated into the barn's normal drinking water ring line.
- You should also install a lockable cupboard for medicines, tools etc. This is also the ideal place for the local CalfGuide server provided that it remains dry and dust-free.
- You should be able to look directly into the calf groups from the CalfExpert. You can then immediately compare the information from the lists with a glance at the calves.
- You should insulate the suction lines additionally even if the calf feeder has a frost protection function. Furthermore, make sure that the water supply line to the automatic feeder is frost-proof.
- A door into the calf pen directly next to the feeding station gives you quick access to the pen during your daily inspection rounds and allows you to train new calves more quickly.
- Consider future extensions of the feeder. Prepare for the easy installation of additional feeder stalls by allowing for the space, a raised base, and the conduits that will be required.

The following pages show a few examples of installation options of the CalfExpert with HygieneStations.

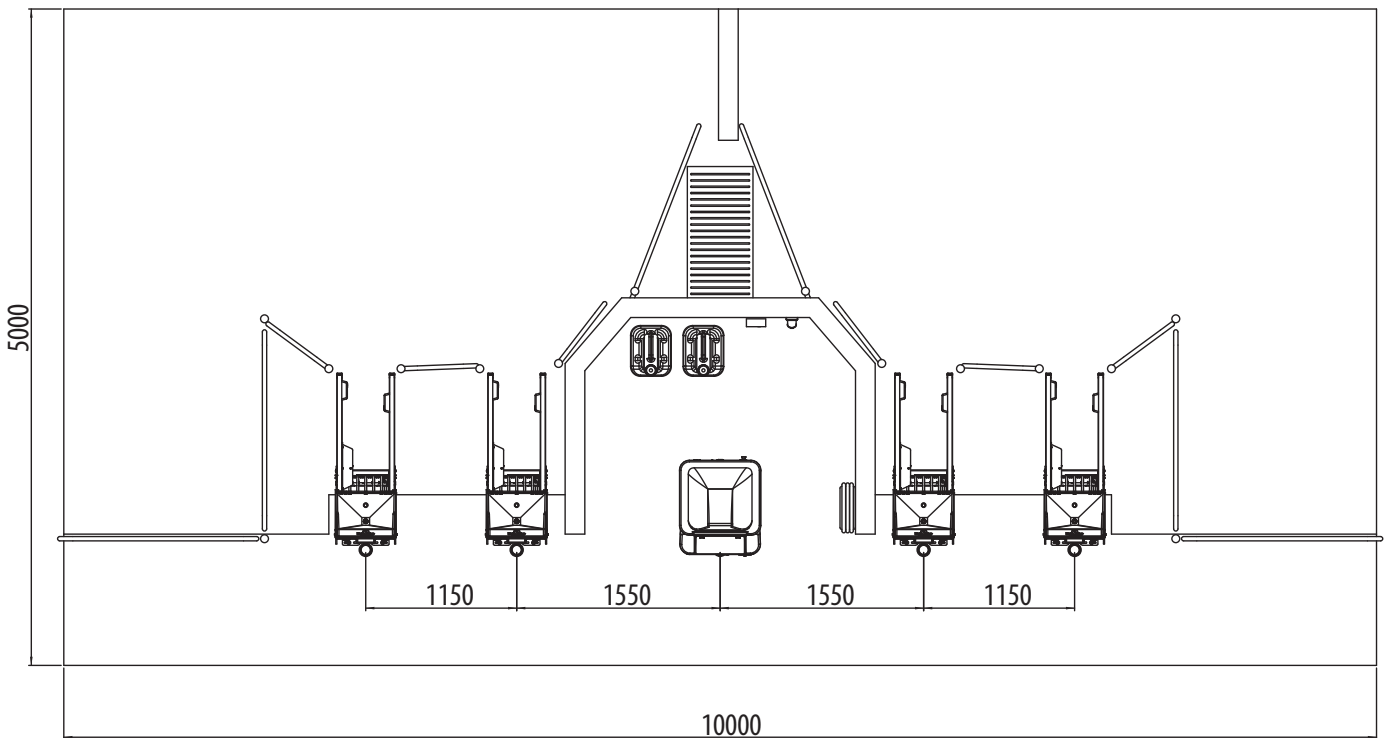
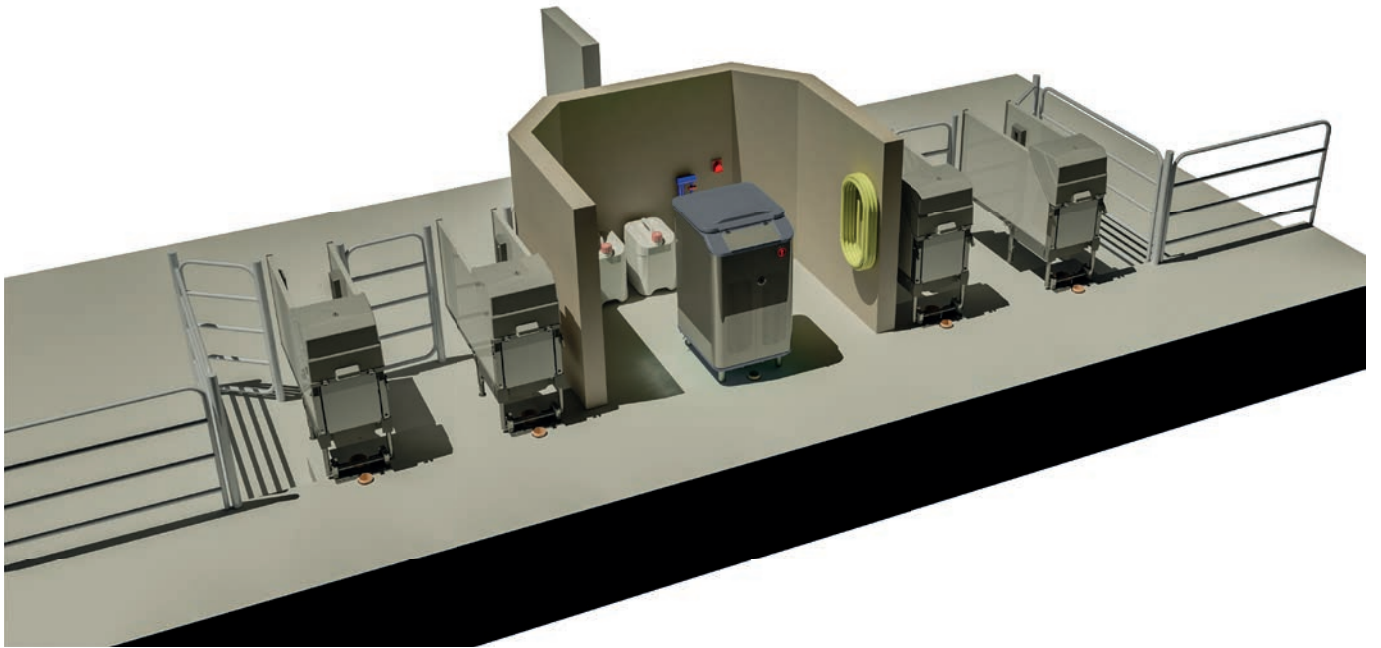

CalfExpert with 4 HygieneStations (two stations per group), access to the calf pen between the HygieneStations

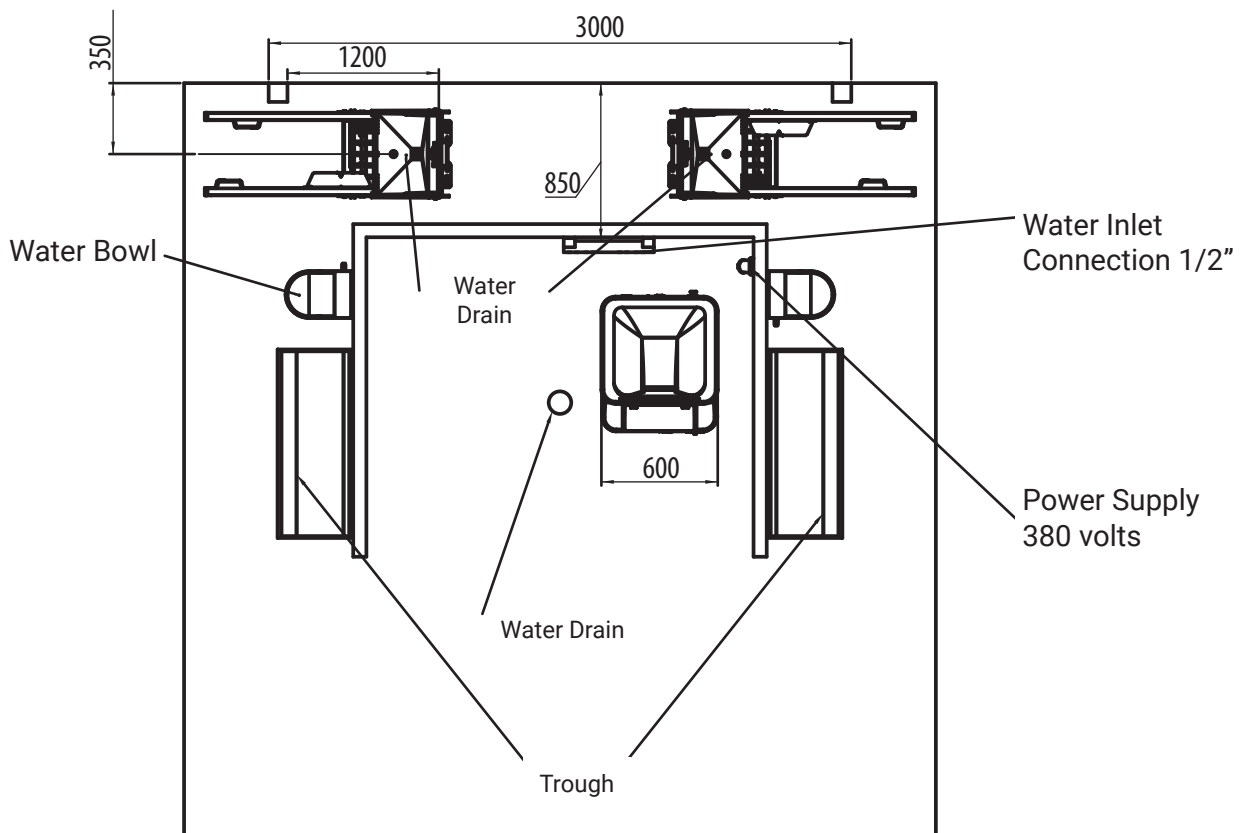
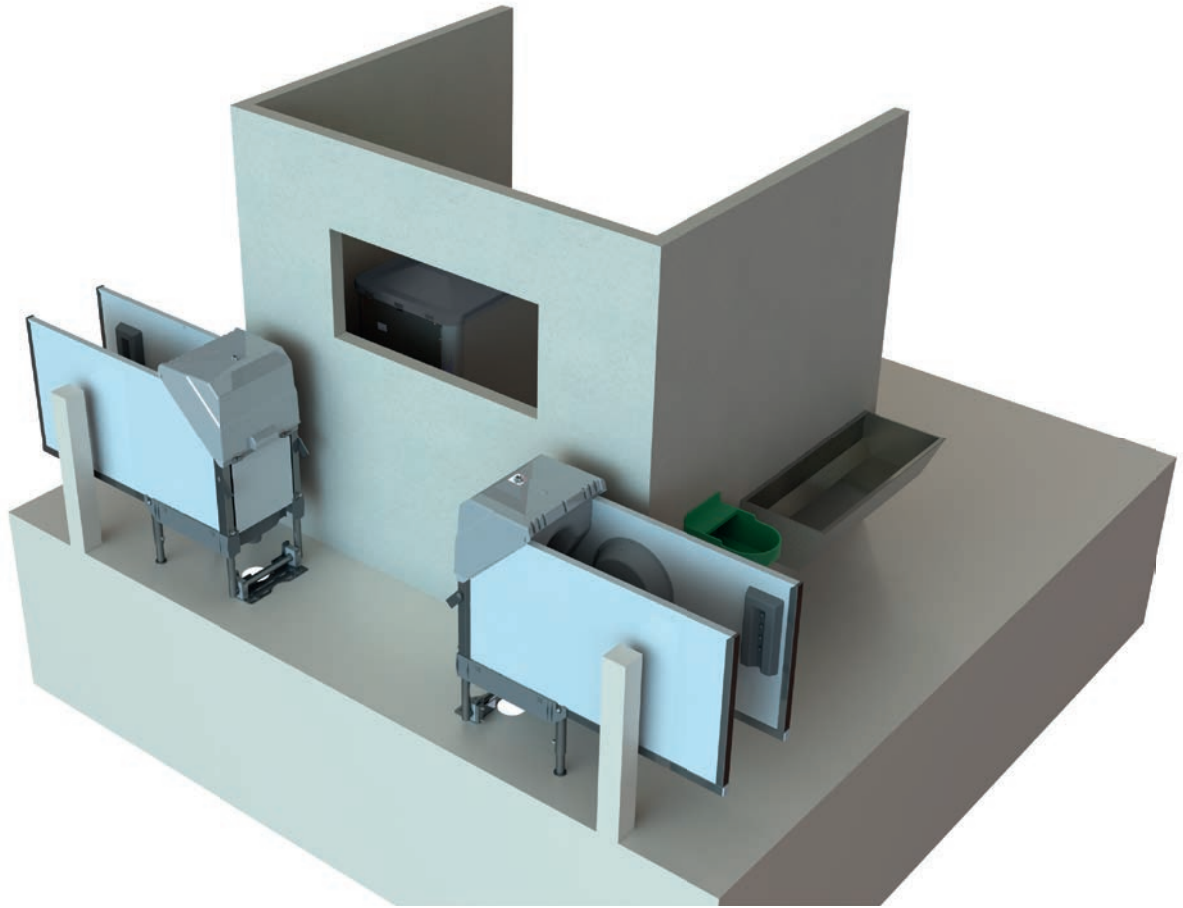

CalfExpert (in the service compartment) with 2 HygieneStations outdoors

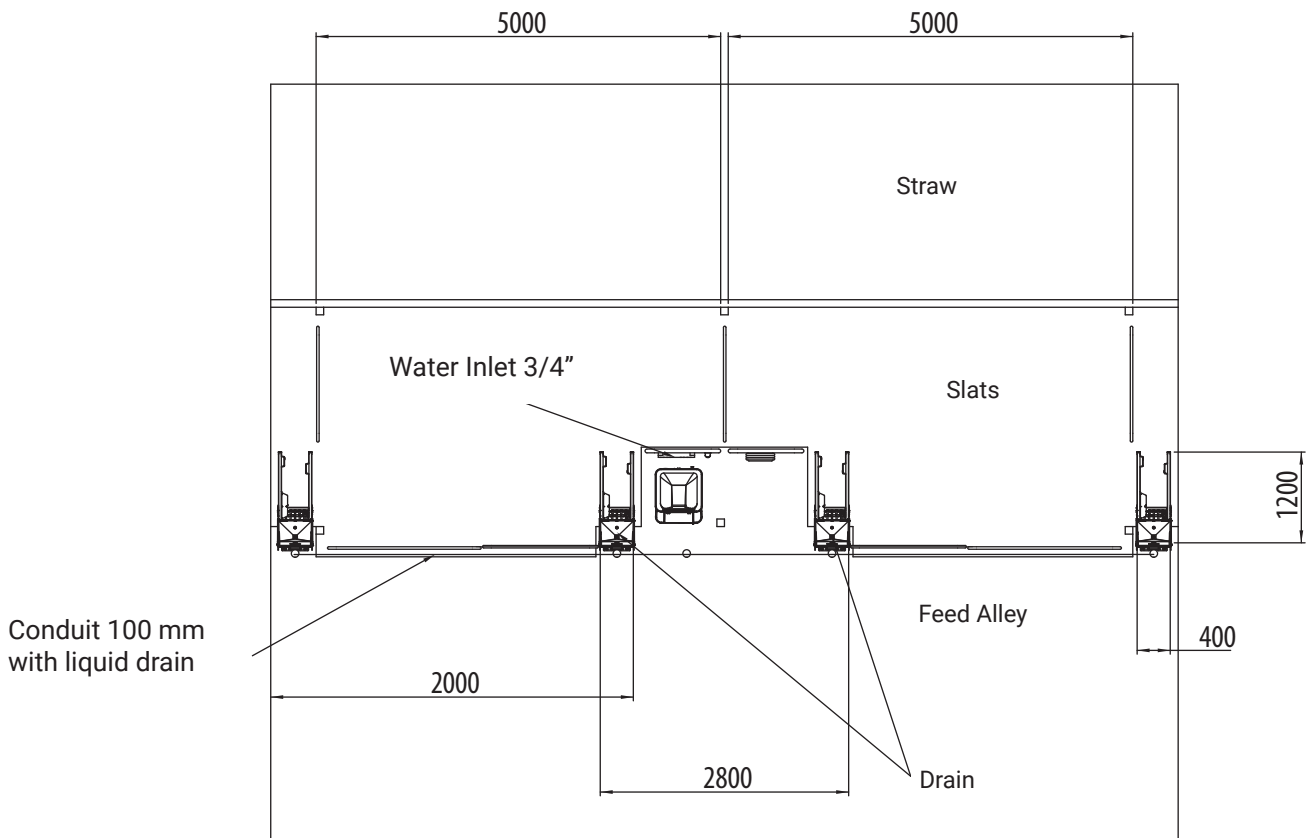
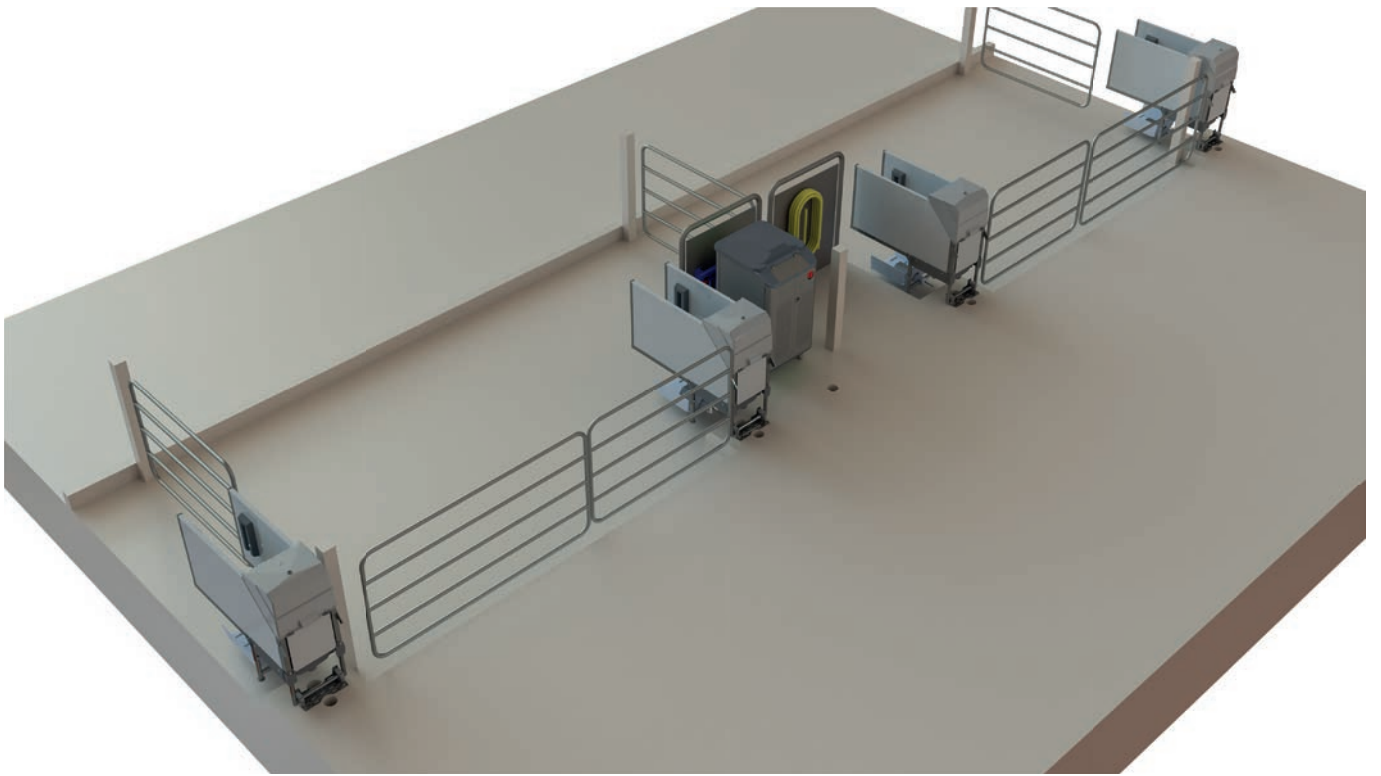

CalfExpert with 4 HygieneStations (one station per group), distance of farthest HygieneStation is 7 m

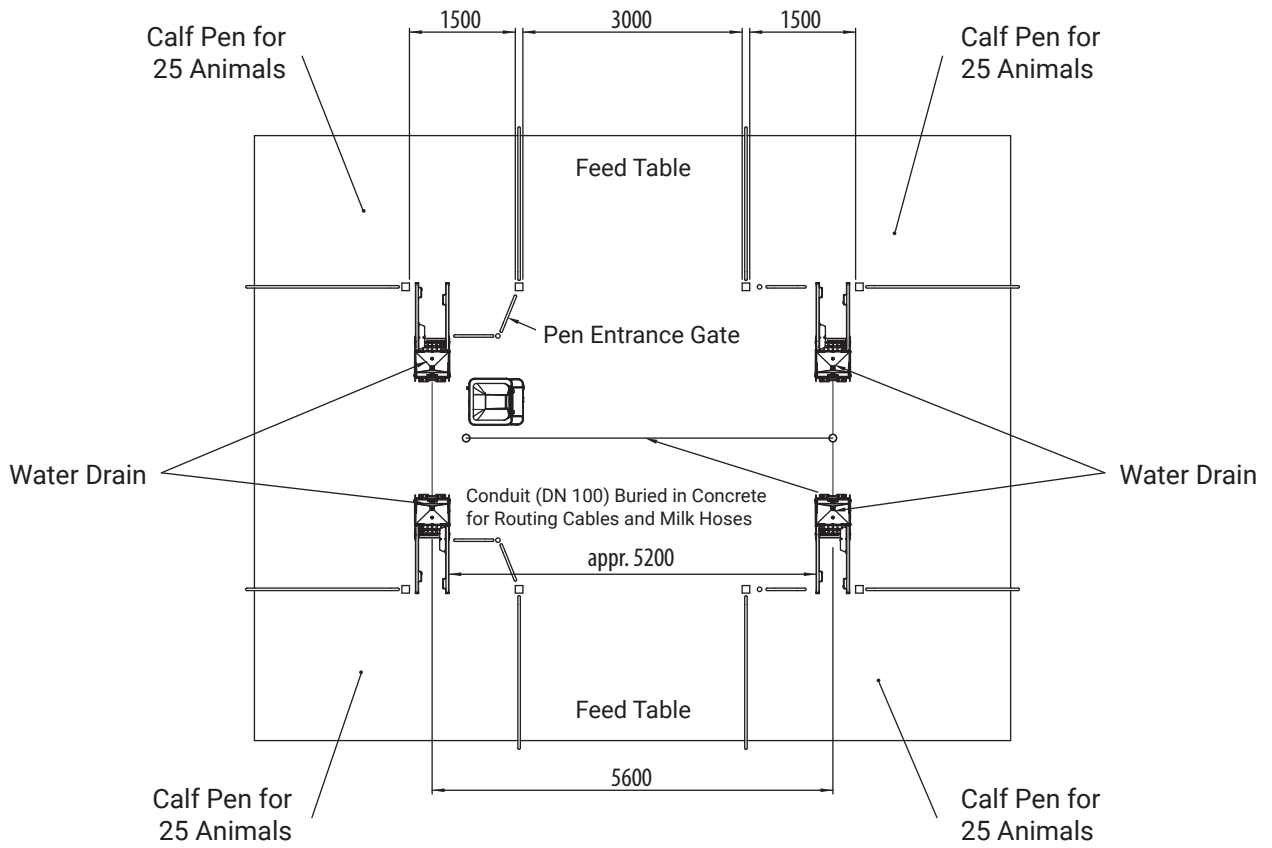
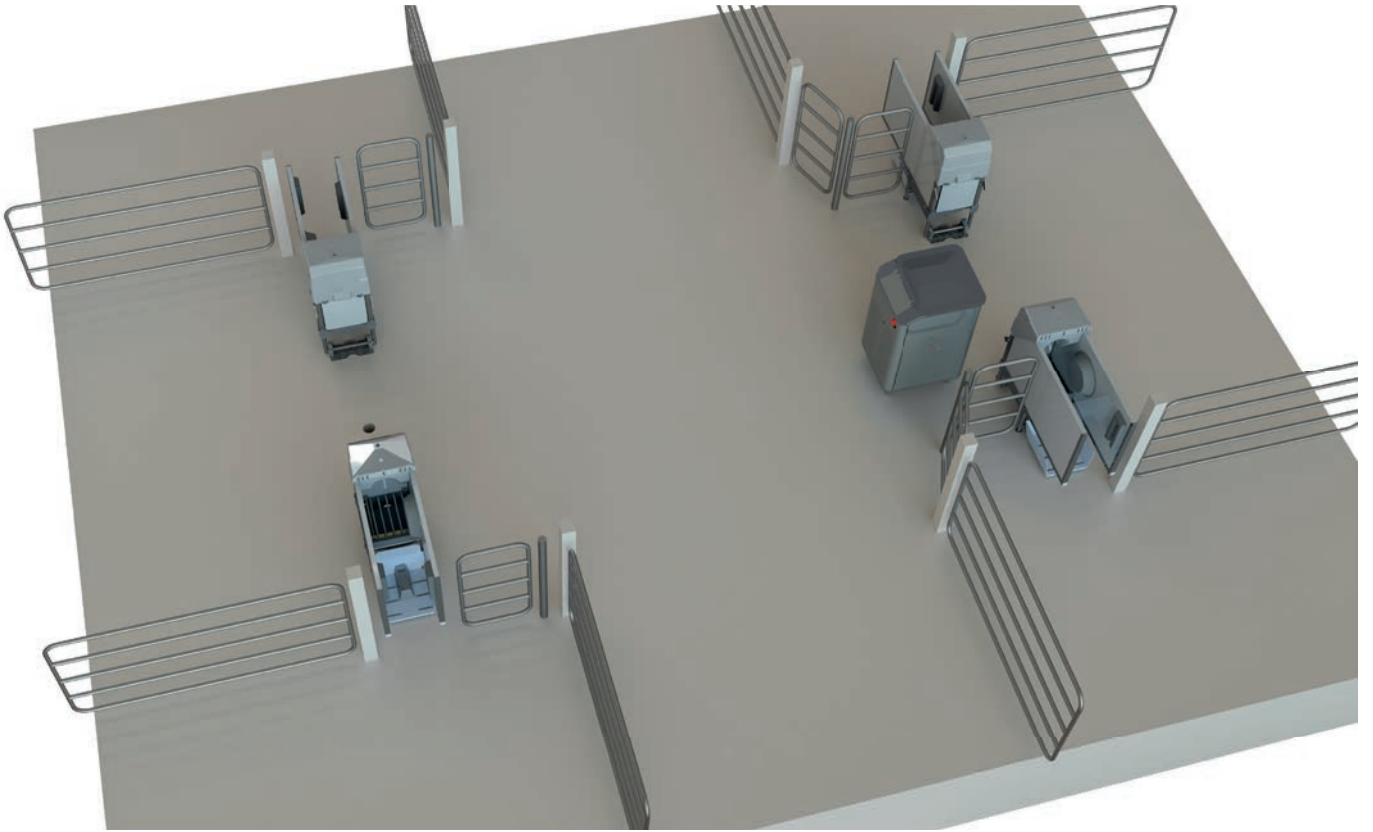

CalfExpert with 4 HygieneStations and central feed table



Practical tips on calf husbandry

When can I move my calves into the outdoor pen?

Right away, actually! Dry the calf properly after birth to avoid hypothermia, especially in the winter, and move it to the well-littered individual igloo. It can be kept there during the colostrum phase until it is fit enough for the group and is drinking well. When to introduce the calf to the group depends on the feeding programme you use. With intensive feeding (metabolic programming), it is recommended to change the stall after approx. 3 weeks. Calves can join a group after only 7-14 days of age with restrictive feeding programmes. However, it should be noted that calves are sensitive to stress during this period, because the immunity protection of the first colostrum administration drops sharply and the calf's own immunity is often not yet sufficiently developed.

Rearing calves in winter

Don't be afraid of low temperatures. Housing calves in igloos has stood the test of various climates around the world. Calves adjust ideally to their environment, in winter too!

Consider the following points:

- Get the calves used to the natural climate outdoors as early as possible (see above).
- Do not neglect the fact that more energy is required in the winter. Up to 40 % more energy needs to be supplied via milk when temperatures drop below freezing.
- Make sure that the bedding is always dry and add bedding material regularly. Dry bedding reduces the loss of energy experienced by lying calves.
- It is advisable to offer added protection to small, weak, and sick calves by making them wear a calf jacket. This body cover will reduce the energy demand that the diet must supply by up to 30 %.
- Always provide fresh water in the winter too. It should be possible to heat the drinker bowls.
- Offer your workers a warm jacket and gloves, maybe the kind with removable finger tips. Bear in mind that humans are much more sensitive to the cold than the calves they are attending to.

Effectiveness of Sanitation Measures to Bedding Material

New bedding regularly added to the old bedding is only superficial and merely creates the impression of cleanliness. Bacteria populations do not decrease much. Even mucking out reduces the bacteria load only by half. It is only high-pressure cleaning, drying, and, finally, disinfecting the surface that provides real protection against bacteria loads that are too high

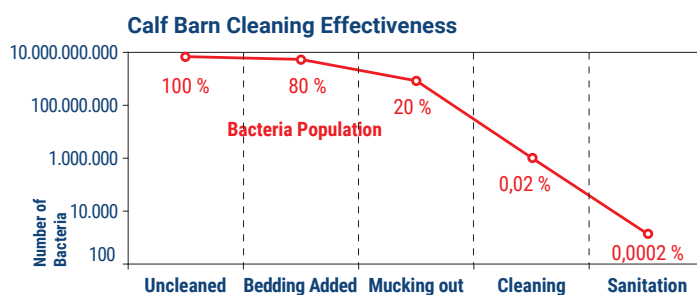

How Do I Clean My Calf Pens and Igloos Properly?

In the cleaning process, a high-pressure cleaner disperses large amounts of dirt and increases the ambient humidity in the barn. This promotes the growth of bacteria. Therefore:

- Clean the calf pens and Igloos in a dedicated washing area away from the barn.
- Provide for an all-in all-out group principle in individual igloos as well. You are then able to clean and disinfect the total area.
- Apply the disinfectant only to dry surfaces.
- Leave the cleaned and disinfected pen empty for several days. Ensure that cleaned pens do not become contaminated (no animal traffic etc.).
- Bedding with a highly alkaline lime content (e.g. Desical®) can sustainably lessen the development of germs.



Planning an igloo barn

What are the advantages of an igloo pen over a conventional fixed pen?

Outdoor housing has the lowest germ count of any type of calf housing. The wind drives all harmful gases and bacteria out of the calf area, providing a healthy environment for the calves.

Pens with natural or forced ventilation show enormous germ contamination in the air breathed. The table below shows which loads can be expected:¹

	Exposure to germs in colony-forming units (CFU) per m ³ of air
Outdoor air	100 - 1,000 CFU / m ³
Clean office air	1,000 - 2,000 CFU / m ³
Well ventilated barn	10,000 - 15,000 CFU / m ³
Calf pens in the calf area	25,000 - 3,000,000 CFU / m ³

Conventional calf pens are therefore highly contaminated with harmful gases and germs. They can be improved by good ventilation (hose ventilation has proven successful here), but they do not come close to the results of outdoor air.

Furthermore, an igloo pen, whether fixed or mobile as a veranda or calf garden, is a very cost-effective solution. While a Holstein calf barn, for example, can easily cost € 1,500 – € 2,500 per calf bay, an igloo pen costs € 650 - 850 per bay.

The mobility of the veranda and calf garden are also an advantage on farms that are constantly developing. This is because a new cow shed or feeding hall may be built tomorrow where the calf pen is today. This is not a problem with mobile systems.

We have prepared the following tips for planning your igloo pen:

How do I position the igloo in relation to the wind direction?

Since the H&L Igloo offers protection for more than three sides, the wind direction is of secondary importance. However, the following points should still be considered when planning the Igloo housing design:

- Place the Igloo in such a way that one of its sides faces the prevailing wind direction (e.g. when West winds prevail, the entrance should face North or South). This will ensure continued protection inside the micro-climatic zone even when the wind turns by 180 degrees.
- Ensure that the igloo is adequately covered so that precipitation is kept away from the bedded area and does not run into the litter. Furthermore, a roof shades the Igloo from the hot summer sun, thereby keeping the temperature inside down. Based on all these considerations, a West-East orientation of the roofing structure, with the Igloo positioned north of the roof, would be ideal.
- Always take the situation on site into account. Buildings, hedgerows or trees may affect the displacement of the air and make the wind all of a sudden blow from another direction.

Is it necessary to protect the outdoor resting area?

Precipitation is usually not a problem if you provide sufficient roof overhang (approx. 1 m roof overhang for a roof height of 3.5 - 4 m) Even in very windy locations, do not start closing the sides of the IglooSystem. This would possibly send the wind in the wrong direction. And every wall means that the rate of eliminating bacteria and providing fresh air is lower.

If extreme draughts have to be faced, a proven method is shutting off the resting area up to the height of the fencing. The lying calves are then protected, and yet the wind ensures good air quality inside the "barn".

The following pages show some drawings with variants for igloo pens. Contact your local H&L partner if you are planning such a barn. They will be happy to assist you

¹ Prof. Dr Ken Nordlund, University Wisconsin, Madison, USA, 2014

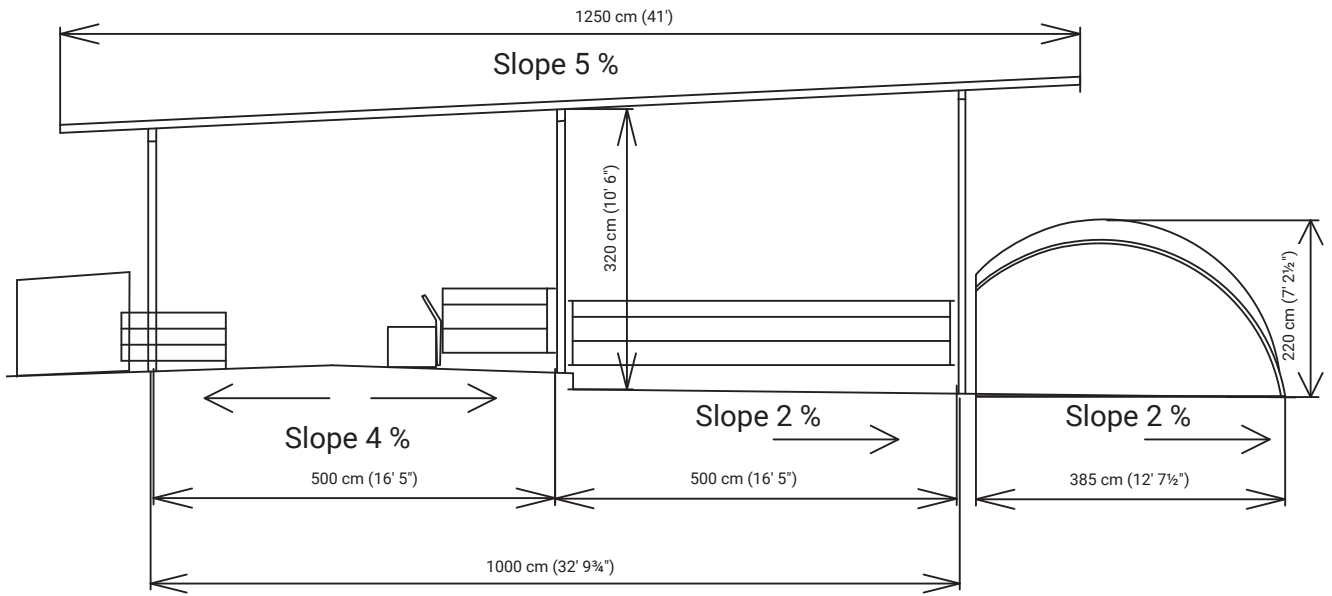

Lateral View of IglooSystem

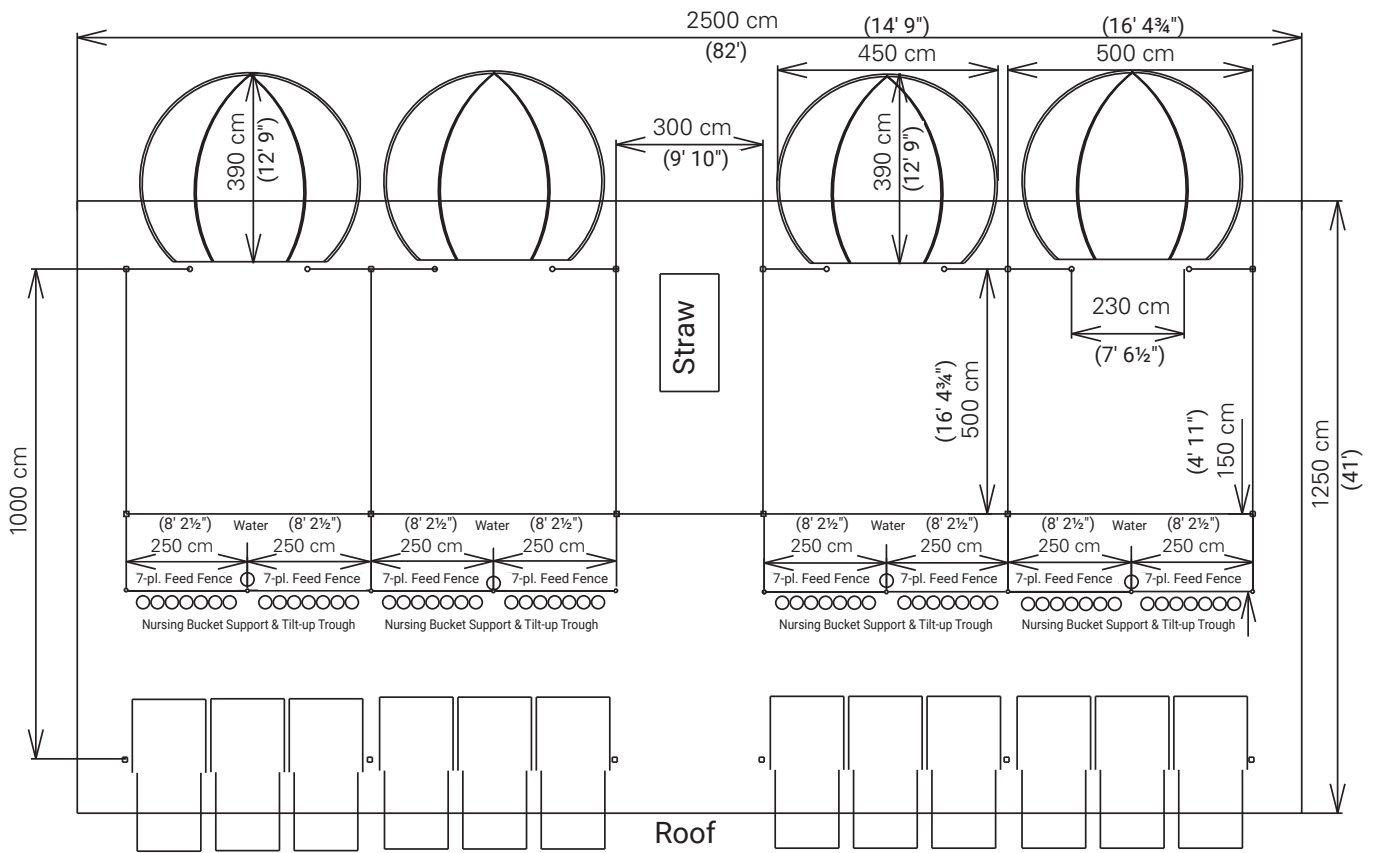

IglooSystem with integrated FeedFences

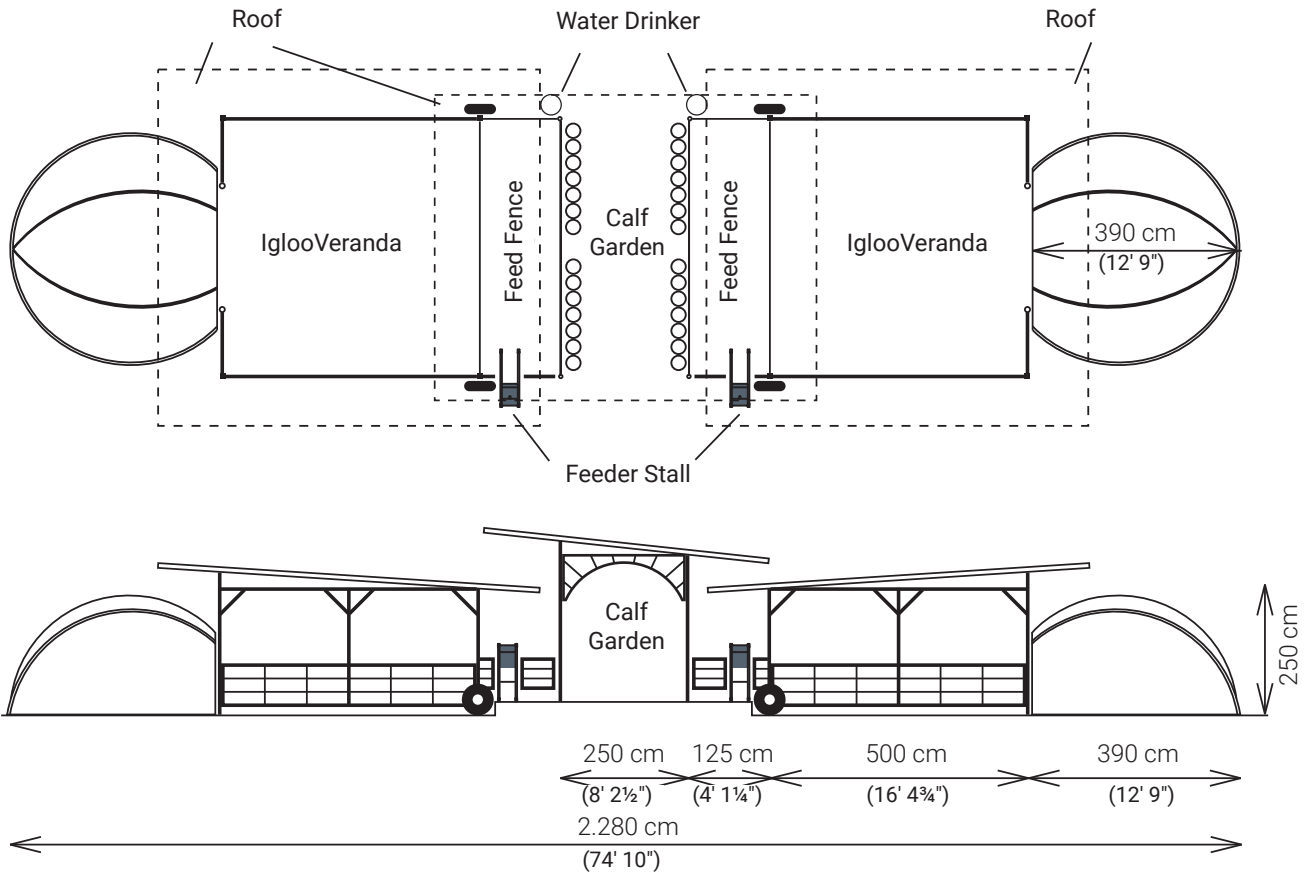

Smart solution: A combination of IglooVeranda and CalfGarden to include an CalfExpert

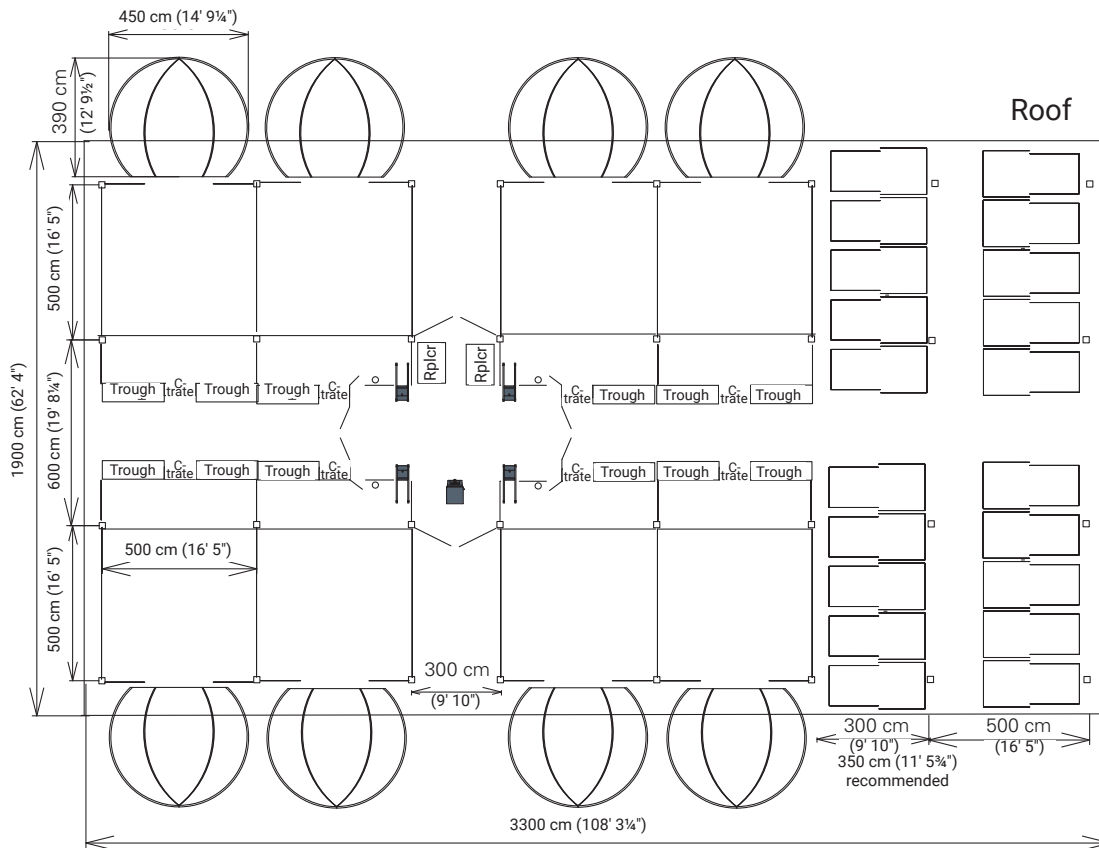

IglooSystem for 140 Calves



Service, training, events

We want our products to make your daily work in the calf barn more successful and less strenuous. But that is not the whole story! For you always need humans to put successful concepts into practice. Therefore, we care enormously for all people who contribute to your success in the calf barn.

Your dealers/our sales partners

Our goal is to offer customers everywhere in the world, or at least in regions where calves are raised, the same highly professional advice that our customers next door, in Northern Germany, have come to appreciate. To be able to guarantee this quality, we have established a strong global dealer network and we invest regularly in their training.

Your contact in an emergency/our service partners

Even the best equipment needs regular maintenance. Our local service partners handle this, ensuring that your operation

runs smoothly. Every service person in the world who looks after your H&L product was trained by us, attends regular advanced training classes, and can access our multilingual, on-line service portal with an expert knowledge base that assists in troubleshooting and provides all the necessary documentation. Of course, all service partners work in close contact with us and have the full support of our own service team. Working together, we find a solution to every issue!

You/our customers

Our calf manual, study trips for our customers, lecture events on topics of modern calf rearing...

In everything we do, we try to give you suggestions and ideas to facilitate an even more professional approach to calf rearing. Contact us or the regional dealer to learn what is available in your vicinity. Or take a look at our website www.holm-laue.com where we regularly inform you about all our news.

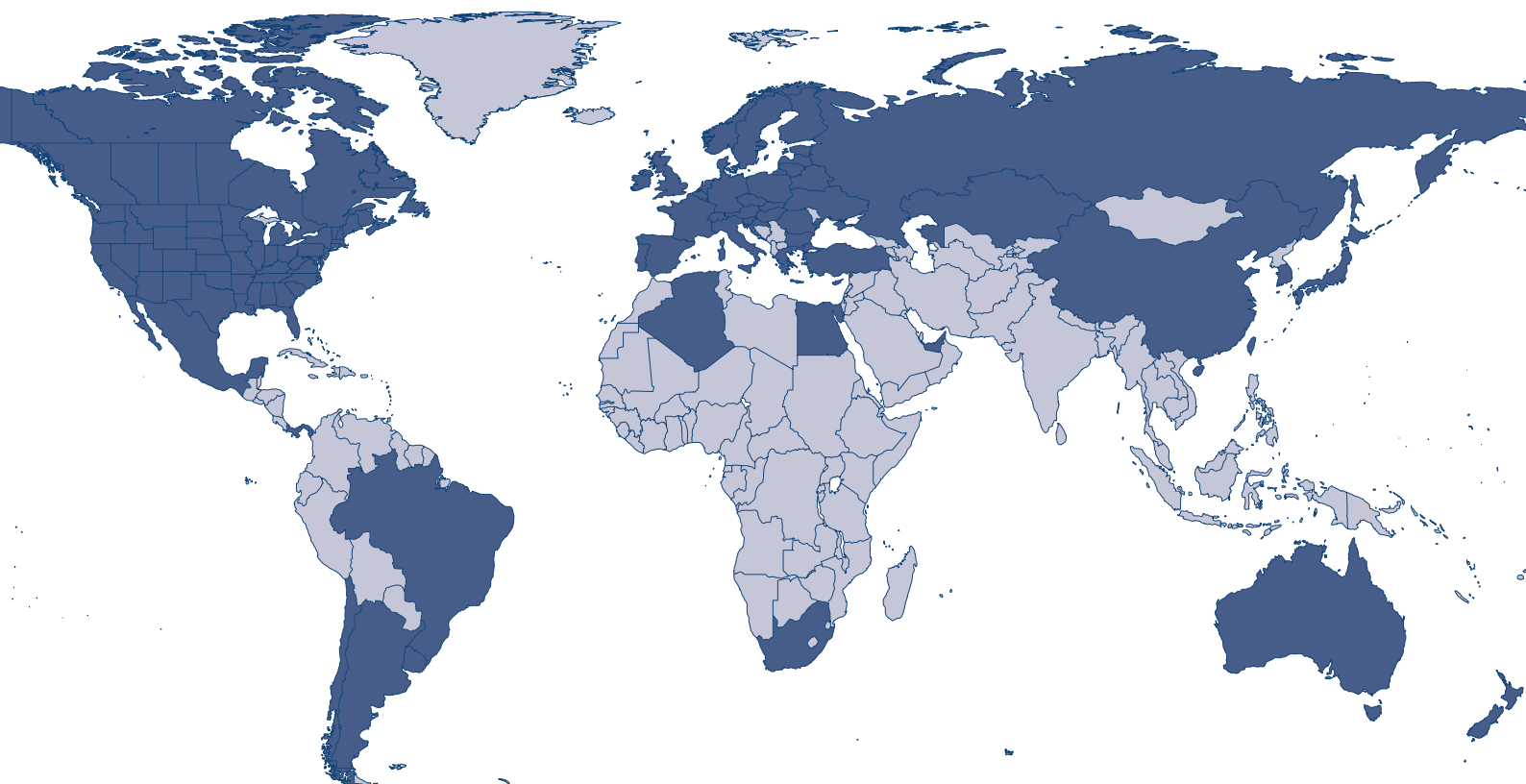



Holm & Laue GmbH & Co. KG
Moorweg 6
24784 Westerrönfeld
Germany

Phone: +49 (0) 43 31 20 174 - 0
Fax: +49 (0) 4331 20 174 - 29
Email: info@holm-laue.com
Web: www.holm-laue.com

We wish to thank those companies and our customers for providing us with the photographic material.

Photograph credits

Holm & Laue, Calvex, Calf-Tel, Schleswig-Holstein Chamber of Agriculture, Elenathewise - Fotolia.com, goodluz/Shutterstock.com, Production Perig/Shutterstock.com, Iakov Filimonov/Shutterstock.com, iStock.com/JMichl

Calf Manual 8th Edition
Subject to errors and modifications.

Nominal charge: € 16

The product information in this manual contains descriptions or performance characteristics which in specific cases do not always apply or which can change as a result of development of the products. Required performance characteristics are only binding if they have been specifically agreed when concluding the contract. Availability and right to make technical changes reserved.

The test results described in this manual cannot be replicated in practice in every case. This is due to local conditions and management measures.

All product designations may be brands or product names of Holm & Laue GmbH & Co. KG or other companies. Their use by third parties for their own purposes can contravene the rights of the owners.



Holm & Laue GmbH & Co. KG

Moorweg 6
24784 Westerrönfeld
Germany

Phone: +49 (0) 4331- 20 174 - 0
Fax: +49 (0) 4331- 20 174 - 29

E-mail: info@holm-laue.com